

### Attrezzo per lo sgancio rapido del tubo flessibile del riscaldamento

Ford heating hose disconnecting tool



216 000

#### Dati tecnici - Informative

Per:  
 Ford Focus 2.0 L ( 2012 - 2016 )  
 Ford Escape / Kuga 2.0 L EcoBoost ( 2013 - 2016 )  
 Pratico attrezzo per lo sgancio di questi accessori che sono vicini al firewall dietro il motore e sono difficili da girare

### Strumento di prova tenuta dell'impianto di raffreddamento del sistema di generazione Ibrido

Hybrid generation cooling system test instrument



216 010

0 - 10 Bar

### Termometro ad immersione

Diving thermometer



216 032 Diam. 5 mm - L. 200 mm - 0° - 160° C

### Set prova tenuta radiatori universale



216 033

Pz 18

In valigetta

### Tappo con gommino ad espansione regolabile, per tester sistemi di raffreddamento

Universal Cooling System Test Adaptor

Utilizzabile solo con i nostri kit prova radiatori 216 033 e 216 034 di pag. 118



Ø 30



Ø 37,5



216 03430

Tappo con gommino

#### Dati tecnici - Informative

Per l'adattamento rapido, semplicemente girando la ghiera a mano come in figura 1, si ottiene l'espansione del gommino dal Ø 30 al Ø 37,5

#### Adattatori - Optional adaptor



216 03435

Gommino adattatore 35 - 40 mm

216 03440

Gommino adattatore 40 - 45 mm

216 03445

Gommino adattatore 45 - 50 mm

**Set prova tenuta radiatori Universale, con attrezzo a depressione per il rapido riempimento dei radiatori**

Radiator pressure tester & Vacuum type cooling system



216 034 Pz 25 In valigetta

Note: ideale per mettere in pressione, riempire e pulire.

**Composizione - Composition**

- 216 033 01  Pompa
- 216 03302  Raccordo Blu - R-123 - R-124
- 216 03303  Raccordo Nero - R-123 - R-125
- 216 03317  Termometro doppia scala C°-F
- 216 03401  Pompa vuoto
- 216 03403  Tappo N°3
- 216 03404  Tappo N°4
- 216 03405  Tappo N°5
- 216 03406  Tappo N°6
- 216 03407  Tappo N°7
- 216 03408  Tappo N°8
- 216 03409  Tappo N°9

**Ricambi per 216 033 & 216 034**

- 216 03410  Tappo N°10
- 216 03411  Tappo N°11
- 216 03412  Tappo N°12
- 216 03413  Tappo N°13
- 216 03414  Tappo N°14
- 216 03415  Tappo N°15
- 216 03416  Tappo N°16
- 216 03417  Tappo N°17
- 216 03418  Tappo N°18
- 216 03419  Tappo N°19
- 216 03425  Cono
- 216 03426  Tubo di spurgo dell'aria
- 216 03427  Tubo del refrigerante

**Adattatori opzionali per 216 033 & 216 034**

- 216 03420  Tappo N°20  
Saab  
EcoPower 9-3, 9-5
- 216 03421  Tappo N°21  
Buick - Cadillac - Chevrolet  
Fiat - Ford - GMC - Hummer,  
Isuzu, Lincoln - Mazda,  
Mercury - Opel - Pontiac -  
Saab, Saturn - Suzuki
- 216 03422  Tappo N°22  
BMW - Mini  
Land Rover

### Set prova-radiatori Zeca

Zeca Radiator tester



216 035 in valigetta - Pz. 18

#### Ricambi - Spare-parts



- 216 037 Tappo 416.10 per: Chevrolet - Ford - Opel - Saab - Vw group
- 216 041 Tappo 416.05 per: Fiat group - Nissan - Mini - Renault - Rover - PSA - Volvo
- 216 042 Tappo 416.45 Per: Mercedes 1
- 216 043 Tappo 416.35 per: Vw Group - Porsche
- 216 050 Tappo 416.40 per: Ford
- 216 051 Tappo 416.24 per: BMW 2
- 216 052 01 Tappo 416.85 per: BMW 1
- 216 052 02 Tappo 416.30 per: Fiat group-Opel-Saab
- 216 052 03 Tappo 416.65 per: Mercedes 2
- 216 052 04 Tappo 416.70 per: Fiat - Suzuki - Toyota - Mitsubishi
- 216 052 05 Tappo 416.80 per: Ford - Mazda - Volvo
- 216 052 06 Tappo 416.55 per: Smart



216 052 07 Gruppo pompa 416.20



- 216 044 Tappo 416.66 Ø 40
- 216 045 Tappo 416.73 Ø 30



- 216 046 Tappo metallico Ø 41,5 - 416.75
- 216 047 Tappo metallico Ø 43,5 - 416.76



216 048 Attacco a baionetta 416.68

### Tappo Mercedes, optional Zeca 416.81 per Kit tester sistemi di raffreddamento Zeca 415

Adaptor Zeca 416.81 for Kit Zeca 415

Utilizzabile solo con il kit prova radiatori Zeca 216 035



216 05208 Tappo opzionale x Mercedes

### Attrezzo a depressione per il rapido riempimento dei radiatori ZECA 417

Cooling device for rapidly radiator filling ZECA 417



216 053 Zeca 417 In valigetta

### Termometro ad immersione a clip

Diving thermometer



216 055 Diam 25 mm - 250 ° F

### Set per scollegare tubi carburante aria condizionata

Set for disconnect fuel and air conditioning pipe



216 058 Ford-Opel - 8 - 9 - 13 - 16 - 19 - 22 mm

### Set scollegamento tubi carburante ed impianti di condizionamento

Set of wrench for conditioning and gasoline tubes



216 059 5/16" - 3/8" - 1/2" - 5/8" - 3/4" - 7/8" - 1/4"

### Set 4 pz. scollegamento tubi carburante per raccordi angolari

Set of wrench for gasoline connectors



216 060 Alluminio anodizzato - 5/16" - 3/8" - 1/2" - 1/4"

### Set sganciatori tubi climatizzatori con molle springlock

Springlock set



216 061 in valigetta

#### Composizione / Composition

4 sganciatori springlock Rosso-Blu-Nero-Bianco  
4 sganciatori a pinza Rosso-Blu-Nero-Bianco  
40 springlock (10x) G6 - G8 - G10 - G12

### Set universale per impianti di condizionamento

Fuel & air conditioning line disconnect set



216 065 Pz 22 In valigetta

### Chiave poligonale aperta per dadi radiatori

Wrench for radiator



216 070 29 mm

### Estrattore puleggia climatizzatore Fiat - Alfa - Lancia

Extractor for conditioning pulley Fiat - Alfa - Lancia



216 072 22x1.5

### Kit estrazione climatizzatore SANDEN



216 080 In valigetta

### Kit per installare e rimuovere climatizzatori

For installation and removing air conditioned

Acciaio Cr. V.



216 081 Pz 4 Valigetta

#### Dati tecnici - Informative

- Bussola con inserto intagliato mm 2.2 Att.1/4"  
- Bussola con inserto intagliato mm 3.2 Att.1/4"  
- Bussola SW 12 Att.1/4"  
- Bussola SW 15 Att.1/4"

**DIGITECH**  
ITALIA

### Attrezzo universale per valvola ricarica climatizzatori R12 & R134A

Valve core removers and installer R12 & R134A



mm 135

216 082

In bustina

### Antigelo / refrigerante UNIVERSALE (certificato) Prodotto approvato per officine DEKR

Compatibile con:  
Tutte le marche  
Tutti i modelli  
Tutti i colori  
Facile da usare, facile da scegliere

Pre-miscelato pronto all'uso,  
Protegge fino a - 37° + 129°

Un pieno di Prestone  
garantisce  
5 anni o 240.000Km



Rabbocca o sostituisce il liquido radiatore di qualsiasi tipo di motore (ghisa - alluminio) e con qualsiasi colore antigelo / refrigerante già inserito sia su motori benzina che diesel. Rabboccando il radiatore mantiene il colore esistente.

216 08301 Tanichetta 1 Lt

216 08304 Tanica 4 Lt.

### Blocca perdite totale

Complete leak stop



216 084

#### Dati tecnici - Informative

Ideale per risolvere i problemi di perdite sugli evaporatori, condensatori, tubi o-ring e in altri componenti sia in metallo che in gomma. Facile da usare, si inserisce anche a impianto carico

\* Non occlude orifici e valvole d'espansione

\* Non danneggia l'impianto A/C

### Lampada con 3 LED bianchi + 1 led raggi UV per la rilevazione delle piccole falle dell'impianto dell'aria condizionata



216 085

Lampada UV

#### Adattatori opzionali - Optional adaptor



216 08501

Occhiali gialli da utilizzare con lampada UV

### Tracciante UV compatibile con: R12 - R134A - R1234YF - Per auto ibride e auto elettriche



IDEALE PER:  
AUTO IBRIDE  
AUTO ELETTRICHE



216 086

ml.350 (46 applicazioni)

#### Dati tecnici - Informative

\*Ideale per rilevare piccole falle dell'impianto aria condizionata degli autoveicoli.

Utilizzato sia nelle stazione di ricerca sia con iniettore manuale

### Tracciante UV compatibile con R134a e HFC

UV tracer for  
R134a e& HFC



216 08675

ml. 7,5 (monodose)

### Olio lubrificante impianti A/C auto

Ester lubricant



216 087 Olio ISO 100 / 1 Lt.

### Olio con TRACCIANTE per lubrificare sistemi A/C auto con refrigerante R134a e R12

Oil for A/C Cond. system with R134a refrigerant



216 08701 Barattolo L.1

Studiato per lubrificare sistemi A/C nuovi retrofittati funzionanti con R134a e HFC. Formula speciale per una migliore performance del sistema, superiore capacità di lubrificazione, migliore miscelazione con i refrigeranti, maggiore protezione al compressore

### Lubrificanti PAG per impianti AC con: R134A - R1234YF - Per auto ibride e auto elettriche



IDEALE PER:

AUTO IBRIDE  
AUTO ELETTRICHE



216 08710 Lt.1 SENZA TRACCIANTE  
216 08711 Lt.1 CON TRACCIANTE

Dati tecnici - Informative

\*Ideale per rilevare piccole falle dell'impianto aria condizionata degli autoveicoli.  
Utilizzato sia nelle stazioni di ricerca sia con iniettore manuale

### Olio Pag sintetico al 100% specifico per R 134 A

PAG oil



216 088 01 Oil ISO 46 - 1Lt  
216 088 02 Oil ISO 100 - 1Lt  
218 088 03 Oil ISO 150 - 1Lt

Dati tecnici - Informative

Speciale formula che riduce la corrosione interna e l'usura del compressore.

### Olio refrigerante per sistemi aria condizionata che impiegano refrigerante R1234-YF

Refrigerant oil to be used with air conditioning R1234-YF refrigerant



216 08804 ml.250

Dati tecnici - Informative

Olio per R1234-YF  
NON utilizzare questo prodotto in nessun altro sistema A/C

### Olio per R134a, per compressori A/C dei veicoli ELETTRICI / IBRIDI

Electric / Ibrid oil for R134a a/c

IDEALE PER:

AUTO IBRIDE  
AUTO ELETTRICHE



216 08805 ml.250

Dati tecnici - Informative

Formula con alta proprietà dielettrica che evita le scariche elettrostatiche.

Compatibile con gli oli dei produttori:  
ND-11 (Toyota) y 38899RCJA01 (Honda)  
Incontra le specifiche OEM

### Tracciante UV alta definizione per R1234yf

UV tracer high definition for R1234yf



216 08825

ml.237 (32 applicazioni)

### Kit cercafughe elettronico, per controllo perdite in pressione dei sistemi di condizionamento auto



216 08950

In valigetta

#### Dati tecnici - Informative

Dispositivo elettronico per rilevare una miscela di gas Idrogeno (H) al 5% + Azoto (N) al 95%.  
E' inoltre in grado di rilevare i gas refrigeranti R134A - R410A - R407C - R1234yf - R32 - R404 - R502 - R290  
E' dotato di sensore a riscaldamento e microprocessore che garantiscono un segnale preciso.  
Riesce a garantire il rilevamento di perdite inferiori a 5ppm (2gr./anno)

### Kit per controllo perdite in pressione dei sistemi di condizionamento auto



216 08910

In valigetta

#### Ricambi - Spare parts



216 089

Bombola di Azoto95% e Idrogeno 5%  
La bomboletta non ricaricabile consente la pressurizzazione dell'impianto e la ricerca delle microperdite.  
Pressione massima di riempimento 110 Bar  
Pressione di prova PH 165 Bar

### Chiave ritegno puleggia compressore Denso climatizzatori Fiat Punto

Anti freezer gravity tester



216 090

### Tubi in linea con rubinetto e depressore da 1/4" per stazioni di ricarica. Lunghezza tubi mm 1800



216 09201



Alta pressione

216 09202



Bassa pressione

### Attacco rapido con volantino connessione 1/4" SAE

Quick coupler fitted with 1/4" SAE. M con



216 09401 Rosso Alta pressione

216 09402 Blu Bassa pressione

### Adattatori opzionali - Optional adaptors



216 09410 Riduzione F 1/4" - M 3/8" SAE

### Attacco rapido lungo per BMW, Volvo, Ford galaxy. R134A

Quick coupler for BMW, Volvo, Ford



216 09403 ● Alta pressione

### Attacco rapido con volantino connessione 1 Per R1234-YF

Quick coupler



216 09405 ● Bassa pressione

216 09406 ● Alta pressione

### Densimetro per antigelo

Anti freezer gravity tester



216 102 Universale

### Densimetro per antigelo ECOPARAGEL

Anti freezer gravity tester



216 105 Universale

### Demineralizzatore con cartuccia in resina per produrre fino a 100 Lt di acqua



216 150 Demineralizzatore

216 151 Cartuccia in resina

### Dati tecnici - Informative

Pressione di alimento  
Temperatura di alimento:

Max 3 bar  
Min.1° - Max 50°C



**DIGITECH**  
ITALIA



### Set chiavi filtro olio - Pz 9

Oil filter wrench set - Pcs 9



217 000 Pz 9 In valigetta

#### Composizione - Composition

1° Attacco 3/8" Lati 14 Misura mm 64,5 Tacche 3  
utilizzo: Allion, Auris, Corolla axio / fielder / Rumion, Isis, Its, Noha, Premio, Prius, Voxy, Wish

2° Attacco 3/8" Lati 14 Misura mm 74,2  
utilizzo: Audi, Bmw, Ford, Mazda, Toyota, Volkswagen, Porsche, Mercedes (tutti i modelli V6 - V8)

3° Attacco 3/8" Misura mm 63 / 83  
utilizzo: Chiave filtro olio universale

4° Attacco 3/8" Lati 16 Misura mm 86,6  
utilizzo: 335i - 3.0 / 535i - 3.0 / bmw 3 serie (E 90) / X6 - 3.0 / Volvo (1999 - 2006) exc (2005 serie 40 & 50)

5° Attacco 3/8" Lati 14 Misura mm 64,5 Tacche 1  
utilizzo: Toyota 2006 (universale) / 2007 & 2008 V6 / Lexus: 2007 ES 350 - GS 350 - GS 450h - LS 460 - RX 350 / Lexus: 2008 LS 600h L

6° Attacco 3/8" Lati 15 Misura mm 88.8  
utilizzo: Hyundai / Kia

7° Attacco 3/8" Lati 6 Misura mm 27  
utilizzo: Mercedes & Smart

8° Attacco 3/8" Lati 6 Misura mm 32  
utilizzo: Opel vauxhall 4 cilindri / GM, 2,2L ecotech X10XE - X12XE - Y17DT - Y17DTL / Mercedes HGV'S e.g - OM 364 - OM 366

9° Attacco 3/8" Lati 6 Misura mm 36  
utilizzo: Mercedes OM 604 - OM 605 - OM 606 - Bmw M52 - 6cil. - M60 - 8cil. - M70 - 12cil. - Mini One - Cooper - Coopers - Ford 6Lt. Diesel VW VR6 (maggioranza Pickup)

### Chiave filtri olio a fascia

Band wrench for oil filter



217 005	In esaurimento	mm 75 - 80
217 006	In esaurimento	mm 80 - 90
217 007	In esaurimento	mm 90 - 95

### Chiave filtri olio a fascia con manico snodato made in U.S.A.

Band wrench for oil filter cartridge



217 016	Universale	57-73 mm
217 017	Universale	65-83 mm
217 018	Universale	75-95 mm
217 019	Universale	92-111mm

### Chiave filtri olio a fascia leggera con manico snodato

Band wrench for oil filter cartridge



217 021	In esaurimento	73-83 mm
217 022	In esaurimento	87-95 mm

### Chiave filtri olio ed essicatori a fascia regolabile

Band wrench for oil filter cartridge and truck dry cartridge



217 030	Universale	65 - 110 mm
217 032	Universale	100 - 150 mm

#### Ricambi - Spare parts

217 031	Fascia di ricambio mm	65 - 110
217 033	Fascia di ricambio mm	100 - 150

### Chiave filtri olio a fascia fibra telata regolabile

Band wrench for oil filter cartridge



217 037 Universale 70-110 mm  
217 038 Fascia ricambio

### Chiave filtro olio a fascia alta, universale, ideale per macchine da lavoro

1/2" Strap wrench



217 040 In blister

#### Dati tecnici - Informative

Per filtri fino a mm 180  
Attacco quadro di manovra 1/2"

### Chiave filtro olio dentata con cinghia in cuoio

Band wrench for oil filter cartridge



	A	B	C
217 041	Ø 40 - 160	mm 180	mm 20
217 042	Ø 40 - 240	mm 240	mm 25

#### Ricambi - Spare-parts

217 041 01 Cinghia in cuoio per 217 041  
217 042 01 Cinghia in cuoio per 217 042

### Chiave filtro a fascia

Strap oil filter wrench



217 043 Chiave filtro con attacco multiplo

#### Dati tecnici - Informative

Chiave molto robusta per filtri macchine, furgoni con Ø fino a 300 mm  
Ideale per lavorare dove manca lo spazio  
Con 3 tipi di attacco: Quadro 3/8" - Quadro 1/2" - Esagono mm 21

### Chiave filtri olio a doppia catena sottile

Double Chain wrench for oil filter cartridge



217 051 Universale - 1/4" - 60-120 mm

217 052 Catena di ricambio

### Chiave filtri olio a doppia catena sottile

Double Chain wrench for oil filter cartridge



217 053 Universale - catena da 1/4" - 60-120 mm

217 053 01 Universale - catena da 1/4" - 60-160 mm

#### Ricambi - Spare-parts

217 054 Catena per 217 053

217 054 01 Catena per 217 053 01

### Chiave a catena doppia sottile per filtri olio

Oil filter wrench with double chain

Att. 1/2"



217 053 10

Ø 60 - 120

217 053 11

Ø 60 - 160

### Chiave filtri olio a doppia catena

Double Chain wrench for oil filter cartridge



217 055 Universale - 3/8" - 60-120 mm

Ricambi - Spare-parts

217 056 Catena di ricambio 58 passi

### Chiave filtro a catena doppia

Double chain wrench for oil filter



217 058 mm 60 - 160

Ricambi - Spare-parts

217 059 Catena di ricambio 88 passi

**DIGITECH**  
ITALIA

### Chiave filtri olio a banda e catena

Band and Chain wrench for oil filter cartridge



217 061 Universale - 80-110 mm

Ricambi - Spare-parts

217 061 01 Catena con fascia di ricambio

217 061 02 Fascia ricambio senza catena

217 062 Catena di ricambio senza fascia

### Chiave filtri olio a banda e catena con ingranaggio

Band and Chain wrench for oil filter cartridge with gear



217 063 Universale - 1/2" - 80-110 mm

Ricambi - Spare-parts

217 064 Catena di ricambio

### Chiave filtri olio a catena con ingranaggio

Chain wrench for oil filter cartridge with gear



217 065 Universale - 1/2" - 60-110 mm

217 066 Catena di ricambio

217 067 Universale - 1/2" - 60-140 mm

217 068 Catena di ricambio

### Chiave filtri olio a catena regolabile

Chain wrench for oil filter cartridge



217 071 Universale - 60-110 mm

Ricambi - Spare-parts

217 072 Catena di ricambio

### Chiave filtri olio a doppia catena

Double Chain wrench for oil filter cartridge



- 217 073 Universale - 3/8" - 60-110 mm
- 217 07301 Universale - 3/8" - 60-140 mm

#### Ricambi - Spare-parts

- 217 074 Cat. ricambio 217 073
- 217 074 01 Cat. ricambio 217 073 01

### Chiave a fascia alta resistenza per filtri olio-aria



- 217 078 Ø 105 - 120 Att. 1/2"
- 217 079 Ø 115 - 135 Att. 1/2"
- 217 080 Ø 130 - 145 Att. 1/2"

### Chiave filtro a battere con 3 denti taglienti per essiccatoio TRUCK

Vedi anche TRUCK Sez.7



- 217 082 Chiave con tre tacche

#### Dati tecnici - Informative

Ø esterno 155 mm  
Ø interno 137 mm  
Attacco quadro da 1/2"

### Chiavi di grande potenza per rimozione filtri TRUCK

Tool remove filter for Truck

Vedi anche TRUCK Sez.7



- 217 08302 Per filtri olio Ø 100 - 110 mm Att:1/2"
- 217 08303 Per filtri olio Ø 110 - 125 mm Att:1/2"
- 217 08304 Per filtri essiccatore Ø 125 - 140 mm Att:1/2"

### Chiave filtri olio a pinza

Plier wrench for oil filter cartridge



- 217 087 Universale registrabile - 60-90 mm
- 217 088 Universale registrabile - 85-115 mm

### Chiave autoserrante reversibile per filtri olio

Reversible filter wrench



- 217 090 Ø 66 - 83

### Chiave filtri olio registrabile

Lever wrench for oil filter cartridge



- 217 093 Universale - 80-105 mm

### Chiave filtri olio autoserrante

Wrench for oil filter cartridge



217 094                      Universale                      60-100 mm

### Serie chiavi filtri olio registrabili

Set wrenches auto locking for oil cartridge



217 095                      Universale - 60-125 mm - Pz. 3

#### Ricambi - Spare-parts

217 096                      Universale - 60-80 mm  
217 097                      Universale - 80-100 mm  
217 098                      Universale - 100-125 mm

### Chiave filtri olio in lamiera di acciaio ad alta resistenza con quadro 1/2" ed esagono da mm 24

Wrench for oil filter cartridge sheet steel with square 1/2" and exagon 24 mm



217 100                      Nissan-Opel-Isuzu-Mazda-Mitsubishi  
14 lati - 64 mm  
217 102                      Mitsubishi - 14 lati - 67 mm  
217 104                      Fiat - 8 lati - 74 mm  
217 106                      Mercedes-Bmw - 14 lati - 75 mm  
217 107                      Fiat Nuova Croma - 16 lati - 75 mm  
217 108                      Opel - 15 lati - 76 mm  
217 110                      15 lati - 80 mm  
217 112                      Fiat - 10 lati - 93 mm  
217 116                      Fiat - 15 lati - 106 mm  
217 118                      Fiat -PALIO EXTRASOTTILE  
15 lati - 106 mm

### Chiave filtri olio in lamiera di acciaio ad alta resistenza con quadro 1/2" ed esagono da mm 24

Wrench for oil filter cartridge sheet steel with square 1/2" and exagon 24 mm



217 122                      Megane - 12 tacche - 76 mm  
217 124                      Laguna - 18 tacche - 86 mm  
217 126                      Peugeot - 45 tacche - 92 mm  
217 128                      Laguna D - 18 tacche - 96 mm



**DIGITECH**  
ITALIA

**Chiave filtro olio a tazza lamiera acciaio con attacco 3/8"**



217 134	Att.3/8'	6 Tacche	66 mm
217 135	Att.3/8"	14 lati -	65-67 mm
Mitsubishi			
217 13500	Att.3/8'	14 Lati	65 mm
217 13501	Att.3/8'	14 Lati	68 mm
217 13502	Att.3/8'	14 Lati	73 mm
217 13503	Att.3/8'	15 Lati	74-76 mm
217 13504	Att.3/8'	15 Lati	76 mm
217 13505	Att.3/8'	8 Lati	76 mm
217 13507	Att.3/8'	12 Tacche	76 mm
217 136	Att.3/8'	30 Tacche	76 mm
217 13600	Att.3/8'	15 Lati	74 mm
217 13601	Att.3/8'	15 Lati	75-77 mm
217 13602	Att.3/8'	15 Lati	78 mm
217 137	Att.3/8'	15 Lati	80 mm
Mitsubishi-Nissan-Suzuky-Toyota ect			
217 138	Att.3/8'	15 Lati	82 mm
Opel			
217 13801	Att.3/8'	15 Lati	80-82 mm
217 13802	Att.3/8'	16 Lati	86 mm
217 13803	Att.3/8'	18 Tacche	86 mm
217 139	Att.3/8'	15 Lati	90 mm
217 13900	Att.3/8'	10 Lati	92 mm
217 13901	Att.3/8'	36 Tacche	93 mm
217 140	Att.3/8'	15 Lati	100 mm
Isuzu			
217 141	Att.3/8'	15 Lati	93 mm
217 14105	Att.3/8'	45 Lati	93 mm
217 14107	Att.3/8'	15 Lati	95 mm
217 14110	Att.3/8'	15 Lati	106 mm
217 142	Att.3/8'	15 Lati	108 mm
217 143	Att.3/8'	18 Lati	108 mm

**Chiave filtro olio a tazza per MAN**

Oil filter key **In lega di Alluminio**



217 144 Att.3/8' 18 Lati 135 mm

**Set 15 pz. chiavi filtro olio a tazza**



217 145 Pz 15 In valigetta

**Composizione - Composition**

14Lati	Ø65	Dayatsu - Toyota
14Lati	Ø68	Mazda - Subaru
14Lati	Ø73	Toyota
15Lati	Ø74/76	Fram
14Lati	Ø76	Mercedes - BMW
15Lati	Ø80	Nissan - Honda
15Lati	Ø93	VW - Renault
36Tacche	Ø93	Motorcraft
14Lati	Ø65/67	USA - CANADA
15Lati	Ø80/82	Honda - Mazda
15Lati	Ø90	Isuzu - Mitsubishi
15Lati	Ø75/77	GM - Ford
30Tacche	Ø76	Motorcraft
15Lati	Ø100	Isuzu - Vix - Holder - M3/8 - F1/2

**DIGITECH**  
ITALIA

## Set 30 pz. chiavi filtro olio a tazza

Set oil filter cap wrench



**217 146** Att.3/8" & 1/2" In valigetta Pz.30

### Composizione - Composition

mm	N°Lati	mm	N°Lati	mm	N°Lati
66	tacche 6	76	30	93	36
65	14	76	8	93	45
65 - 67	14	78	15	95	15
68	14	80	15	96	18
73	14	80 - 82	15	100	15
74	15	86	16	106	15
74 - 76	15	86	tacche 18	108	15
75 - 77	15	90	15	108	18
76	tacche 12	92	10		
76	14	93	15		

Ragno 3/8" - 1/2"

Adattatore mm 65 - 120

### Ricambi - Spare parts

217 134	Att.3/8'	6 Tacche	66 mm
217 13500	Att.3/8'	14 Lati	65 mm
217 13503	Att.3/8'	15 Lati	74 - 76 mm
217 13505	Att.3/8'	8 Lati	76 mm
217 13507	Att.3/8'	12 Tacche	76 mm
217 13600	Att.3/8'	15 Lati	74 mm
217 13803	Att.3/8'	18 Tacche	86 mm
217 13900	Att.3/8'	10 Lati	92 mm
217 140	Att.3/8'	15 Lati	100 mm
217 141	Att.3/8'	15 Lati	93 mm
217 14105	Att.3/8'	45 Lati	93 mm
217 14107	Att.3/8'	15 Lati	95 mm
217 14110	Att.3/8'	15 Lati	106 mm

## Chiave filtri olio in lega leggera PURFLUX con esagono di manovra da mm. 24

Wrench for oil filter cartridge aluminium - 24 mm hexagon



Materiale  
lega Zinco - Rame

**217 150** Twingo-Opel 1500 D - 6 tacche 66 mm

**217 152** Megane - 6 tacche 76 mm

**217 154** Laguna - 18 tacche 86 mm

**217 156** Laguna D - 18 tacche 96 mm

## Chiave filtro gasolio Peugeot - Citroen HD. 2 - 2.2

Fuel filter socket

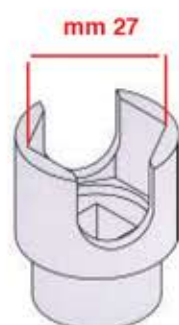

**217 167** mm 27

## Set chiavi in acciaio per filtri olio ad immersione

Steel set Oil filter cap wrench



**217 168** Att. 3/8" - mm: da 24 alla 38 - Pz 7

### Composizione - Composition

**Att. 3/8"** mm 24 - 27 - 29 - 30 - 32 - 36 - 38

## Set chiavi per filtri olio ad immersione

Set Oil filter cap wrench



**217 170** Att. 3/8" - Pz 3 - in valigetta

### Ricambi - Spare

**217 170 01** Att. 3/8" - mm 27

**217 170 02** Att. 3/8" - mm 32

**217 170 03** Att. 3/8" - mm 36

### Chiavi per filtri olio ad immersione

Set Oil filter cap wrench



217 170 24	Att. 3/8"	mm 24
217 170 27	Att. 3/8"	mm 27
217 170 30	Att. 3/8"	mm 30
217 170 32	Att. 3/8"	mm 32
217 170 36	Att. 3/8"	mm 36
217 170 38	Att. 3/8"	mm 38

### Chiave filtro olio Fiat, con esagono mm 32

32 mm Exagon - Oil filter offset wrench



217 171 Esagono chiuso mm 32

### Chiave filtro olio ricavata da tondo pieno

Acciaio Cromato



217 172 Fiat - 8 lati - 74 mm

### Chiavi filtro olio in acciaio saldato con quadro 1/2" ed esagono di manovra mm 24

Oil filter wrench welded steel



217 18600 15 Lati 75 mm  
\*Progettata per le nuove Ford "benzina"

### Chiave filtro olio "MODELLO ALTO" in acciaio saldato con quadro 1/2" ed esagono di manovra mm 24



217 189 01 10 Lati - 93 mm

### Chiave filtro olio in acciaio saldato con quadro 1/2" ed esagono di manovra mm 24

Oil filter wrench solder steel - 1/2"



Zincate



217 180	14 Lati - mm 64
217 182	14 Lati - mm 67
217 184	Fiat - 08 Lati - mm 74
217 185	10 Lati - mm 74
217 18515	MAN 15 Lati 74 mm
217 186	Mercedes-Bmw - 14 Lati - mm 75
217 186 01	Multijet 1.9 - 16 Lati - mm 75
217 187	Opel - 15 Lati - mm 76
217 187 06	14 Lati - mm 80
217 188	Mitsu.-Niss.-Suz.-Toy - 15 Lati - mm 80
217 188 00	16 Lati - mm 87
217 188 01	12 Lati - mm 88
217 188 02	16 Lati - mm 90
217 188 03	16 Lati - mm 92
217 188 05	10 Lati - mm 90
217 188 08	15 Lati - mm 90
217 188 14	14 Lati - mm 84
217 189	Fiat Marea TD - 10 Lati - mm 93
217 190	Volvo - 15 Lati - mm 93
217 190 05	15 Lati - mm 98 -
217 191	Iveco - 15 Lati - mm 106
217 19110	Volvo - Renault - Iveco 15 Lati 107,5 mm
217 192	Isuzu - 16 Lati - mm 118
217 193	18 Lati - mm 136
217 196	9 Tacche mm 92
217 197	9 Tacche mm 95

### Chiave filtro olio in acciaio saldato con quadro 1/2" ed esagono di manovra mm 24

Oil filter wrench welded steel



IVECO



217 19012	12 Lati 103 mm
Per filtri Geotech - Iveco ( DF-887 )	
217 19015	15 Lati 103,5 mm
Per filtri, Aifo - Geotech - Iveco ( 2992544 )	
217 195	15 Lati 140 mm



### Chiave filtro olio in acciaio saldato

Oil filter wrench solder steel



Zincate



217 194 Iveco - Eurocargo

#### Dati tecnici - Informative

Lati 15 - mm 112,5  
Attacco quadro di manovra 1/2"  
Esagono di manovra mm 24

### Chiavi Esagonali chiuse con attacco quadro 1/2" per rimozione filtri olio



1/2"



413 490

Pz.7

Su guida

#### Ricambi - Spare parts

413 49019	mm 19	
413 49022	mm 22	
413 49024	mm 24	Bmw N62, 5/7
413 49027	mm 27	Ford Fiesta 1,4 - 1,6 Tdci, Transit 2,2 - 2,4 - 3,2 2006 Bmw Mini Renault 1.5, 1.9, 2.2, 2.5 Dci Mercedes classe A
413 49030	mm 30	
413 49032	mm 32	*Audi A6 3,2 V6 Tsi - 2004 Opel Astra G, Corsa B, Vauxall VW Polo 1.2, Transporter T5 1.9, 2004 Ford Transit 2.0, 2.4 anni 2000, 2006
413 49036	mm 36	Bmw M52 (serie 3/5), M60 (serie 5/7/8), M73 (serie 7/8) Mercedes M616, 116 Mb/100 Mercedes 220D, C250D, E220D, E250D, E300D, M604, M605, M606 Opel Vectra B 16V - 1998 Vw Lupo 1.2 Tdi, Touareg Tdi, Transporter T5

### Kit chiavi poligonali per cartucce filtro olio difficilmente raggiungibili



217 199

Pz.5

#### Composizione - Composition

217 19924	Chiave singola att.3/4" - Poligono mm.24
217 19927	Chiave singola att.3/4" - Poligono mm.27
217 19932	Chiave singola att.3/4" - Poligono mm.32
217 19936	Chiave singola att.3/4" - Poligono mm.36
217 19938	Chiave singola att.3/4" - Poligono mm.38

### Chiave filtri olio a fascia

Band wrench for oil filter cartridge



217 200	Universale - 75 mm
217 201	Universale - 80 mm
217 202	Universale - 98 mm
217 203	Universale - 110mm
217 204	Universale - 140mm

### Chiave filtri olio a tacca con quadro 1/2"

Wrench for oil filter cartridge



217 215

### Chiave filtro olio VESPA PIAGGIO 50 CC

Band wrench for oil filter cartridge VESPA PIAGGIO 50 CC



217 220

Att. Quadro 1/2" + Esagono 30 mm

### Chiave filtri olio TDCI Ford - HDI Citroen - Peugeot

Oil filter wrench on TDCI Ford - HDI Citroen - Peugeot



217 240 Att. 1/2" Poligono mm. 27

#### Dati tecnici - Informativa

Chiave per smontare e rimontare il filtro dell'olio montati sui motori 2.0 Duratorq TDCI (HDI DW10C) e 2.2 TDCI Duratorq TDCI (HDI DW 12C) su veicoli Ford - Jaguar - Land rover e motori HDI Citroen - Peugeot.

### Set 3 Pezzi per lo smontaggio in morsa del filtro gasolio multijet Fiat e Opel



Ghiera di manovra utilizzabile sia con attrezzo Fiat che Opel

Attrezzo filtro gasolio Fiat Multijet

Attrezzo filtro gasolio Opel Multijet

217 245 Kit Ghiera + Attrezzo Fiat  
217 24510 Kit Ghiera + Attrezzo Fiat + Attrezzo Opel

#### Ricambi - Spare

- 217 24502 Attrezzo filtro gasolio Fiat Multijet
- 217 24501 Ghiera di manovra
- 217 244 Attrezzo filtro gasolio Opel Multijet

### Chiave filtro gasolio vetture Peugeot HDI



217 246

### Chiave filtro gasolio per Ford Transit

Diesel Filter wrench



217 247

#### Dati tecnici - Informativa

Ideale per la rimozione e il montaggio su Transit, Transit Custom e Tourneo Custom 2.2L TDCi

### Chiave per filtro gasolio Vw e Volvo

Diesel filter wrench ( Vw / Volvo )



217 248 In blister

#### Dati tecnici - Informativa

Per:  
Vw Crafter 5 cilindri Diesel dal 2006  
Volvo C30, C70, S40, S60, S80, V50, V60, V70, XC60, XC70, XC90  
OEM: Vw T-50011 / Volvo 9997084  
Attacco 1/2"

### Chiave smontaggio filtri olio e gasolio alta in lega di alluminio pressofusa



217 249 Ø 74 - 14 Lati

### Chiave aperta per filtro gasolio strumentato

Key for fuel filters



217 250 H=120mm 14 lati - mm75

### Chiave filtro a campana pesante



	Attacco	Lati	mm	Altezza
217 251	1/2"	15	141	50

### Chiave filtro olio alta per Toyota

Alluminio



217 252 14 Lati con 1 tacca mm 64,5

#### Dati tecnici - Informative

-Toyota: 207 - 2008 3.5L V6  
 -Lexus: GS300 (2006), IS250 (2006), IS350 /2006, ES350 (2007) GS350 (2007), GS450 (2007), LS460 (2007), RX350 (2007) LS600h L(2000)

### Chiave filtro olio a tazza in alluminio

Wrench for oil filter cup type



217 253 14 Lati con 3 tacche + 3 tacche mm 64,5 Att.3/8"

Toyota 2007 - 2008 V6 / Dal 2006 tutte le Lexus / Dal 2007 ES350 - GS350 - GS450h - LS460 - RX350 / Dal 2008 LS600hI

### Chiave filtro olio a tazza in alluminio per HYUNDAI & KIA

Wrench for oil filter cup type  
100 mm



217 254 15 Lati mm 88,8 Att.3/8"

### Chiave filtro olio per Toyota Mazda

Oil filter wrench for Toyota Mazda

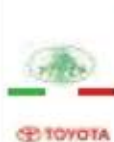

217 255 Att. 3/8" 12 Lati 57 mm  
 \*Chiave per filtro: S51C 13 ZA5 A

### Chiave filtro VAG T 2.0i - TDi - CR

For Audi / Vw / Skoda / Sea T 2.0 - TDi - CR



217 280

### Chiave per manovra bulbo acqua

Wrench for water bulb removal



217 391 29 mm

### Chiave ghiera fissaggio filtro olio

Wrench for oil filter nut fixing



217 392 Alfa 155-164 6 denti 34x24x3.5 4 denti 34x26x5

### Chiave ghiera fissaggio filtro olio

Wrench for oil filter nut fixing



217 393 Alfa 164 - Polig 22 mm

### Chiave ghiera fissaggio filtro olio

Wrench for oil filter nut fixing



217 394 Audi-Polo - 38,5 x 18 x 7

### Chiave ghiera fissaggio filtro olio

Wrench for oil filter nut fixing



217 395 164 TD

### Kit riparazione filetto tappo coppe olio

Kit repairing oil filter cups



217 400 12 Tappi con rondelle

Ricambi - Spare

	Esagono	Esagono femmina	Filetto	Pz
217 400 01	17	-----	13 x 1,5	1
217 400 03	19	-----	15 x 1,5	1
217 400 05	---	8	17 x 1,5	1
217 400 07	---	10	20 x 1,5	1

### Kit in astuccio riparazione filetto tappo coppe olio

Kit repairing oil filter cups



217 400 13	1 maschio + 12 rondelle + 6 tappi - 13 x 1.5
217 400 15	1 maschio + 12 rondelle + 6 tappi - 15 x 1.5
217 400 17	1 maschio + 12 rondelle + 6 tappi - 17 x 1.5
217 400 20	1 maschio + 12 rondelle + 6 tappi - 20 x 1.5
217 400 22	1 maschio + 12 rondelle + 6 tappi - 22 x 1.5

### Kit universale riparazione filetto tappo coppe olio

Oil pan repair master set



217 401

Composizione - Composition

1 maschio + 10 rondelle + 5 tappi	13 x 1.5
1 maschio + 10 rondelle + 5 tappi	15 x 1.5
1 maschio + 10 rondelle + 5 tappi	17 x 1.5
1 maschio + 10 rondelle + 5 tappi	20 x 1.5

### Chiave tappo olio XZN forate, per Audi

Oil cup socket hole XZN

Acc. Cr Mo.  
Cromato



	Att.	XZN	Lunghezza	
217 404	1/2"	16	55 mm	MONOLITICA
217 405	1/2"	16	55 mm	
217 406	1/2"	16	100 mm	

### Kit chiavi speciali per smontaggio e montaggio tappi in plastica dello scarico dell'olio coppa motore montati su motori gruppo VAG Tfsi & TDI

Assembly tool for plastic oil drain plug



217 410 Kit composto da 217 41001 + 217 41002 + 217 41003

Ricambi - Spare parts

217 41001	Chiave con presa a "T"
217 41002	Chiave con Att. Esag.17mm + quadro 3/8"
217 41003	Tappi in plastica di ricambio ( pz.3 )

### Chiave dadi tappo olio

Wrench for oil draining plug



217 413 Fiat - 12 mm

### Kit "diver" per tappi olio in plastica

Plastic oil drain plugs assembly kit



217 411 Pz.5 In box

#### Composizione - Composition

Impugnatura a T da 3/8"

2 prese "slot" da 3/8"

Punta esagonale da 10 mm con codolo esagonale da 1/4"

Punta per tappo olio VAG con codolo esagonale da 1/4"

#### Dati tecnici - Informative

Ford (spina OEM 18711598 e 1830727)

Peugeot / Citroen (spina OEM 9801444780)

BMW (spina OEM 11137605018)

VAG (Tappo coprimozzo OEM 06L 103 801)

### Chiave dadi tappo olio quadro

Wrench for oil draining plug



217 41601 Quadro 9 mm

### Chiave dadi tappo olio sezione triangolare

Triangle wrench oil draining plug



217 418 Triangolare 10 mm

### Chiave dadi tappo olio con doppio quadro

Double wrench for oil draining plug



217 420 Quadro 8 - 9 mm

217 421 Quadro 8-10 mm

### Chiave dadi tappo olio con doppio esagono

Double wrench for oil draining plug



217 423 Audi-Volkswagen 14-17 mm

### Chiave doppia dadi tappo olio e cambio

Twin wrench for oil draining plug and gear



217 425 M 10 mm - F 10 mm

217 426 M 8 mm - F 6 mm

**DIGITECH**  
ITALIA

## Chiave tappo di scarico olio, per Nissan

Oil drain plug socket for Nissan



		Impronta	Lunghezza
217 428	Att.1/2"	mm 23	mm 38

## Chiave filtro differenziale

Differential filter spanner wrench



217 429 In blister

### Dati tecnici - Informative

Poligono 46 mm - Lunghezza chiave 490mm  
 Chiave a "L" indotazione da 5 mm  
 Utilizzabile per: VW5 & 6 / Bora / Golf 4 / Sharan / Skoda - Octavia

## Set chiavi tappo olio

Set of oil draining plug wrenches



217 430 Pz.6 In valigetta

### Ricambi - Spare parts

- 217 43001 Chiave tappo olio doppio Esagono: 5/16" X 3/8"
- 217 43002 Chiave tappo olio doppio Quadro: 8 X 3/8"
- 217 43003 Chiave tappo olio Quadro 11X Esagono 12
- 217 43004 Chiave tappo olio doppio Esagono: 8 X 10
- 217 43005 Chiave tappo olio Quadro 13 X Esagono 14
- 217 43006 Chiave tappo olio doppio Esagono: 17 X 1/2"

## Set chiavi tappi olio



217 431 Att 1/2" Pz 21 In valigetta

### Composizione - Composition

- mm6 - 7 - 8 - 10 - 11 - 12 - 13 - 14 - 5/16 - 3/8"
- mm 8 - 9 - 10 - 12 - 13 - 14 - 17
- Tx10 - Tx45  mm16
- Quadro femmina mm10 - 1 asta con quadro 1/2"

## Set 15 chiavi magnetiche per rimozione tappo olio

Magnetic bit set for oil draining plug



217 432 In valigetta Questo kit permette infatti, grazie alle bussole magnetiche, permette di trattenere i tappi dello scarico olio evitando spiacevoli inconvenienti.

## Imbuto olio universale con pinza autobloccante

Universal oil funnel

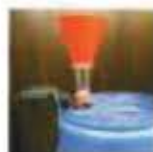

217 438 In blister

### Dati tecnici - Informative

Facilita la ricarica dell'olio grazie alla sua pinza a rilascio automatico autoregolante da Ø 28 a Ø 74

La finestra trasparente consente il controllo visivo del flusso d'olio

### Apri lattina

Tank opener



217 440 Universale

### Imbuti per travaso olio motore Fire (compatibili con prolunga)

Wrench for lambda sensor ( mm 22 )



- 217 441 Imbuto circolare corto per taniche da 1 litro
- 217 442 Imbuto quadrato corto per taniche da 4 litri
- 217 441 01 Imbuto circolare lungo per taniche da 1 litro
- 217 442 01 Imbuto quadrato lungo per taniche da 4 litri

### Prolunghe filettate (compatibili con prolunga)



- 217 443 Prolunga filettata per imbuti Fire
- 217 444 Prolunga filettata per imbuti Fire su vetture Multijet
- 217 447 Prolunga filettata per Multiair e EVO 2

### Prolunga flessibile per imbuti travaso olio motore Fire da utilizzare su furgoni e vetture Multijet con tappo olio in profondità



217 446 Lunghezza mm 470

### Prolunga flessibile + Prolunga filettata per motori Multiair



217 447 01 Lunghezza mm 510

### Imbuto olio lt. 2.2 con sistema anti-reflusso



Made in Germany



217 445

In scatola

### Imbuto olio Lt.2,2 con sistema anti refluxo Motori Audi - Seat - Skoda - Vw...etc

Funnel oil with anti reflux



217 44510  
Con doppio terminale intercambiabile



217 44510

Con doppio terminale

In scatola

**DIGITECH**  
ITALIA

### Kit astine controllo olio trasmissione motori

Mercedes transmission oil dipstick set

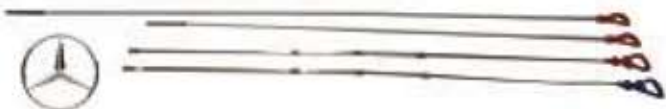

217 454 Kit 4 pz.

Ricambi - Spare parts



217 450 Asta singola

Per cambi tipo: 722.6

Lunghezza: 1220 mm



217 451 Asta singola

Per cambi tipo: 722.7, 716.5

Lunghezza: 920 mm



217 452 Asta singola

Per motori tipo: 103-943, 984, 985-104-111-119-120-137-603-913-963, 97-604-605-606-611-612-613-626

Lunghezza: 930 mm



217 453 Asta singola

Per motori tipo: 112-113-646-647-648

Lunghezza: 930 mm

### Asta rilevamento livello olio Audi A4 & A5

Audi transmission oil dipstick Audi A4 & A5



217 459 NB: La misurazione deve essere effettuata con una temperatura dell'olio di circa 60°

### Astina controllo olio cambio Audi 100

Audi 100 oil dipstick

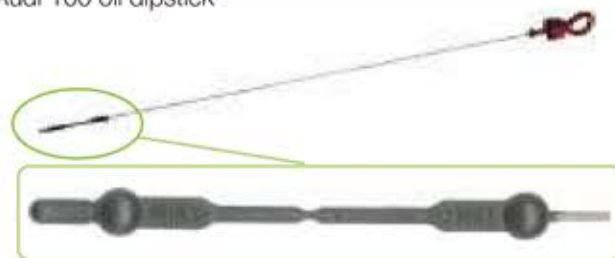

217 460 L= mm 520

### Bussola esagonale fresata per sonda lambda



217 485 Freemont Motore 2.0 140cv Multi Jet

\*Esagono mm 17

\*Fresata mm 6

\*Attacco 1/2"

### Chiave per sonda lambda

Wrench for lambda sensor



Att: 1/2"



Esagono mm 29

1/2"

mm 80

217 493 Esagono mm 29



**DIGITECH**  
ITALIA



### Chiave sensore temperatura FAP montato su motori Renault DCi 1.5 e Ford



**217 494** Lunghezza chiave mm 120 Per Renault

**217 49455** Lunghezza chiave mm 74 Per Ford

Dati tecnici:

Esagono: mm 14 - Fresata: mm 6

Att. posteriore di manovra: Esagono mm 17

### Chiave a bussola snodata aperta con doppia impronta, a impugnatura piegata. Ideale per sonde lambda

Angled socket, double impression



**217 495**

In blister

#### Dati tecnici - Informative

Chiave a doppia impronta "Poligono + "Esagono" mm.22  
Lunghezza mm.250 - Angolo a 30° - Peso450gr.

### Chiave sonda lambda pesante con doppio quadro di manovra



**217 496** 1/2" - 22 mm

### Kit bussole per sonda lambda ( mm 22 )

Wrench for lambda sensor ( mm 22 )



**217 497** Pz 5

#### Composizione - Composition

	Attacco quadro	Lunghezza	Esagono
1°	1/2"	mm 150	mm 22
2°	1/2"	mm 80	mm 22
3°	1/2"	mm 48	mm 22
4°	3/8"	mm 30	mm 22
5°	Ravviva Filetti M 18 x 1,5		

### Chiave manovra sonda lambda con doppio quadro

Wrench for dismantling Lambda sensor



**217 498** 1/2" - 22 mm

**217 503** 3/8" - 22 mm

### Chiave poligonale manovra sonda Lambda

Wrench for dismantling Lambda sensor



	Attacco	Lunghezza	Poligono aperto
<b>217 499</b>	1/2"	80 mm	20 mm

### Bussola per sonda lambda

Lambda socket



	Attacco	Lunghezza	Esagono aperto
<b>217 500</b>	3/8"	80 mm	22 mm
<b>217 501</b>	1/2"	80 mm	22 mm
<b>217 502</b>	1/2"	110 mm	22 mm

### Chiave per sonda lambda extralunga - Impact

Wrench for dismantling lambda sensor - Impact

Acciaio Cr. M



217 50215

### Chiave poligonale manovra sonda Lambda

Wrench for dismantling Lambda sensor



217 504 20 mm

### Attrezzo per smontaggio molle ritegno tubo di scarico

Tool for removing spring of manifold and muffler pipe



217 505 Golf-Passat

### Utensile allargatubi marmitte catalitiche

Tool for pipe muffler opening



Utilizzare avvitatore per espansione

217 509 Universale - 41-62 mm

### Utensile allargatubi marmitte

Tool for pipe muffler opening



217 511 Universale - 22-40 mm

217 513 Universale - 38-62 mm

217 515 Universale - 54-84 mm

#### Ricambi - Spare parts

217 512 Segmento - 217 511

217 514 Segmento - 217 513

217 516 Segmento - 217 515

217 517 Perno completo - 217 511

217 518 Perno completo - 217 513

217 519 Perno completo - 217 515

### Pinza rimuovi supporti in gomma dei tubi si scarico

Exhaust hanger removal plier



mm 58



217 522

In blister

### Pinza per collari giunzione tubi di scarico

Hose clamp plier



521 685

In blister

#### Dati tecnici - Informative

Lunghezza pinza: mm 300

Apertura becchi: Chiusa mm 15 - Aperta mm 54

### Pinza per collari giunzione tubi di scarico.



521 687

Per gruppo PSA

In blister

#### Dati tecnici - Informative

Lunghezza pinza: mm 309

Apertura becchi mm 60 - Cava introduttrice: mm 12,2

### Attrezzo per lo stacco dei tubi di scarico

Tool off pipes



217 525

In valigetta

### Chiave a gancio per gommini sostegno tubi scappamento

Wrench for holding muffler pipe rubbers



217 529 Volkswagen-Audi-Mercedes-Nissan-Fiat-Opel

### Kit per smontaggio / montaggio catene

Chain cutter & riveting tool suitable

Smontaggio Montaggio



218 000

Dati tecnici - Informative

\*Il kit è indicato lo smontaggio / montaggio catene delle moto, ma si rende praticamente adatto a tutti i tipi di catene essendo dotato di 3 perni intercambiabili di diverso diametro



Ø 3,5 - Ø 5 - Ø 6

### Attrezzo smonta / monta catene

Disassembling / assembling chains tool



700 180

Dati tecnici - Informative

Con viti a puntale e viti a punta conica per allargare il piolo forato Il set è composto di punzone rivettatore per catene RIF: 415 - 420 - 428 - 520 - 525 - 530 - 532

### Attrezzo smonta / monta catene di distribuzione

Disassembling / assembling chains tool



700 185

### Attrezzo centrafrizione universale

Universal tool for centering clutch



221 001 Universale

### Attrezzo centrafrizione universale

Universal tool for centering clutch



221 005 Universale

Ricambi - Spare parts

221 006	Perno Piccolo
221 007	Perno Medio
221 008	Perno Grande

### Attrezzo centrafrizione universale

Universal tool for centering clutch



221 010 Universale

### Estrattore volano frizione

Puller for clutch



221 032 Piastra per Innocenti Mini

#### Adattatori opzionali - Optional adaptor



221 033 Kit per Innocenti Mini 3/8" x 24 fil.

221 034 Kit per Innocenti Mini 8 x 1

221 035 Kit per Innocenti Mini Rover 10 x 1.5

### Chiave poligonale per dado fissaggio albero primario cambio Ford Transit

Key for transmission gearbox Ford transit



221 045 Att. 3/4 Poligono 46 mm

### Kit per testare i volani a doppia massa

Dual mass flywheel - Wear testing tool

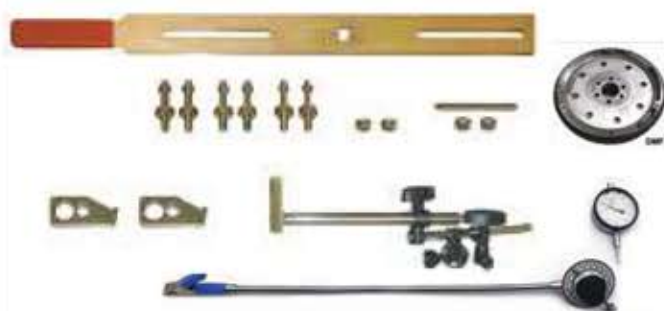

221 047

In valigetta

#### Dati tecnici - Informative

Universalmente adatto per veicoli dotati di Volano a doppia massa (DMF).

Strumento indispensabile per i test di usura dei volani a doppia massa (DMF).

Le prove possono essere eseguite direttamente sul veicolo con la frizione rimossa.

Come regola generale per i volani a doppia massa si deve sempre verificare l'usura nel caso di sostituzione di una frizione. Test professionali sono essenziali per i volani, che se risultano deteriorati possono danneggiare la nuova frizione, la scatola del cambio e la trasmissione.

- Applicazione universale.
- Risparmio di tempo notevole.
- Lo strumento è facile da utilizzare.
- Lavorazione professionale e precisa.

**DiGITECH**  
ITALIA

### Set montaggio frizione Luck e Sac

Self adjusting clutch tool set ( 3 hole pitch )



**221 048** in scatola  
Completo di 3 serie di perni per renderlo adatto a quasi tutti i veicoli;  
Audi-Bmw-Mercedes-Opel-Renault-Volvo- Vw- ecc...

### Ricambi - Spare parts

**221 04901**  
Ø6



**221 04902**  
Ø7



**221 04903**  
Ø8



**221 049 01** Set 3 perni Ø6

**221 049 02** Set 3 perni Ø7

**221 049 03** Set 3 perni Ø8

### Kit per montaggio frizioni Sac - Lak

Self adjusting clutch tool set



**221 050** In valigetta

\*Nuova piastra con 3 e 4 punti si fissaggio e dotata di nuovo perno di centraggio regolabile

### Estrattore volano frizione

Puller for clutch



**221 051** Peugeot

### Minipinza per seeger senza fori per accessi difficili

Mini-plier for seeger without holes



**221 054** 50 mm

### Pinza anelli elastici senza fori su cuscinetti giunti omocinetiche e cambio beccuccio piegato

Lock ring plier



**221 055** Fiat-Iveco Fuller

### Pinza anelli elastici senza fori montati su giunti omocinetiche e cuscinetti cambio. Becchi diritti

Straight tip lock ring plier



**221 055 01** Fiat-Iveco Fuller

### Pinza anelli elastici senza fori su cuscinetti giunti omocinetiche e cambio beccuccio diritto

Lock ring pliers



**221 056** Fiat - Iveco fuller

**Pinza per anelli elastici senza fori in acciaio forgiato manici plastificati**

Plier for elastic rings without holes



221 058 mm 220 Punte rette

**Pinza per anelli elastici senza fori in acciaio forgiato manici plastificati**

Plier for elastic rings without holes



221 059 mm 220 Punte angolate

**Estrattore perno frizione DUCATO 2.8 JTD**

Joint clutch puller for DUCATO 2.8 JTD



221 060 L=120mm

**Attrezzo estrazione cuscinetto spingidisco per frizione Ducato**

Joint clutch puller - Ducato



221 070

**DiGITECH**  
ITALIA

**Kit per smontaggio frizioni duplex DGS - VAG**

Dual clutch removing kit

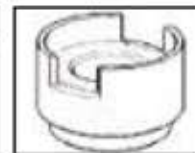

221 090

In valigetta

**Dati tecnici - Informative**

Ideale per la rimozione del gruppo frizione manual gearbox 08D con trasmissione a 6 velocità del seguente modello:  
Tuareg dal 2003

Ideale per la rimozione del gruppo frizione Dual clutch gearbox OAM con trasmissione a 7 velocità dei seguenti modelli:  
Golf dal 2004  
Golf plus dal 2005  
Audi A3 dal 2004

**Adattatori opzionali - Optional adaptors**



221 080

Chiave per blocco / sblocco cambio DGS a 7 marce doppia frizione Vw - Audi

**Adattatori opzionali - Optional adaptors**



New



221 081

Calibro per regolare le frizioni K1 e K2 su trasmissioni Vag DGS

### Chiave ghiera alberi cambio

Wrench for gear shaft nut



222 014 Ulisse - Ducato - Scudo - 44x41x5

### Chiave per dado albero primario

Wrench for gear main shaft nut



222 020 Alfetta - 30 mm

### Chiave ghiera albero riduttore

Wrench for low Pto ring nut



222 024 Fiat 242 - 44 mm

### Estrattore ingranaggio del cambio 5° marcia su motori Ford

5° Gear extractor Ford engine



222 030

### Coppia attrezzo smontaggio boccole comando cambio

Wrench for auxiliary bearing nut



222 200 Alfa - Citroen - Fiat - Lancia - Peugeot - Toyota

### Attrezzo ad espansione per smontare anello di ritagno assale

Tool for dismounting retaining axle ring



223 001 GM-FWD-Daily

### Battitoio montaggio cuscinetto stagno su semialbero

Device for refitting bear ring on half shaft



223 002 N 500

### Battitoio montaggio cuscinetto stagno su semialbero

Device for refitting bear ring on half shaft



223 004



223 005



223 004 Diam. Est. 34 mm - Diam. Int. 30 mm

223 005 Diam. Est. 34 mm - Diam. Int. 28 mm

### Chiave lunga per differenziale VW - AUDI

XZN tool for shuft nut



223 006 01 XZN 8 x 800 mm

223 007 XZN 10 x 500 mm

223 007 01 XZN 10 x 800 mm

### Chiave esagonale maschio

Wrench male for nuts



223 011 Esagono 8 x 500 mm

### Set chiavi XZN Corte e Lunghe con innovativo attacco

Duo-Drive



**DUO DRIVE**

Att. 1/2"



Hex mm 24



223 013 01

Valigetta Pz 6

#### Ricambi - Spare parts

223 01304	Chiave 1/2" - XZN 14 - Lunga 40 mm
223 01306	Chiave 1/2" - XZN 16 - Lunga 40 mm
223 01308	Chiave 1/2" - XZN 18 - Lunga 40 mm
223 01314	Chiave 1/2" - XZN 14 - Lunga 78 mm
223 01316	Chiave 1/2" - XZN 16 - Lunga 78 mm
223 01318	Chiave 1/2" - XZN 18 - Lunga 78 mm

### Chiave a bussola con maschio XZN per mozzi VW e Audi, e per coperchio scatola differenziale Audi A3 - Vw Touran

XZN tool for shaft nut



Att. 1/2"



Att. 3/4"



M18

223 015 Att. 1/2" tipo impact - M 18x78

223 01502 Att. 3/4" tipo impact - M 18x75

### Chiave per ghiera a 4 denti rimozione ghiera flangia albero trasmissione Mercedes e AR



Att. 1/2"

In blister

223 018

Dente Ø 7,5  
Ø interno dente / dente mm 35  
Ø esterno dente / dente mm 40

### Chiave ghiera flangia cambio al pignone

Wrench for shaft nut to pinion



223 021

Mercedes transporter - 43 x 36 x 8

### Bussola poligonale att.3/4". Per cuscinetto differenziale Land Rover - Volvo

Tools for differential bearing



223 025

Poligono mm 41

\*Ideale per Freelander 2 e Volvo XC70

223 026

Poligono mm 44

\*Ideale per Range Rover

223 027

Poligono mm 46

### Chiave ghiera bloccaggio



223 032

Per flangia sede giunto scorrevole lato propulsore Lancia Flavia-Fulvia - 61 x 51 x 7

### Chiave ghiera ritengo cuscinetti scatola esterna differenziale

Wrench for extern ball bearing box retaining nut



223 037

Panda 30 Nuova 500 - 54 mm



### Chiave ghiera cuscinetti semiasse intermedio

Wrench for internal axle differential



223 042 Per ALFA 155 - mm 43 x 35 x 6.

### Estrattore introduttore albero giunto omocinetico

Introducer for half shaft constant velocity joint



223 051 Alfa 33-155

### Set 3 pinze anelli senza foro su giunto omocinetico

Set 3 plier for circlips without hole for half shaft



223 05210 Pz 3 In scatola

Ricambi - Spare parts

223 05211  Becco Piegato 30°

223 05212  Becco fresato

223 05213  Becco dritto

### Forcella a leva per estrazione semiassi

Rubber for axle



223 058 Nuova Punto

223 060 Ducato

### Attrezzo pneumatico universale per montaggio cuffie

Universal pneumatic tool for mounting rubber seals

**BOOTSLIDER**



223 090 Press. max 8 bar per cuffie orig. "BOOGE" 2.5 Kg

### Cono per inserimento cuffie elastiche

Universal kit seal with cone



223 103 Cono in plastica

### Cono per inserimento cuffie elastiche

Universal kit seal with cone



223 104 Cono + cuffia + grasso + 2 fascette di serie "tipo liscio"

223 10401 Cono + cuffia + grasso + 2 fascette di serie "tipo liscio" + 2 fascette art.521540 "tipo traforato"

Ricambi - Spare parts

223 103 Cono inserimento cuffie

223 105 Cuffia con grasso e fascette "Tipo liscio"

521 540 Kit 2 fascette "Tipo traforato"



### Kit cuffia elastica universale, con grasso e fascette



**223 105** In scatola con grasso e 2 fascette di serie "tipo liscio"

**223 10501** In scatola con grasso e 2 fascette di serie "tipo liscio" + 2 fascette art.521540 "tipo traforato"

### Kit cuffia elastica per furgoni, con grasso e fascette



**223 106** In scatola con grasso e 2 fascette di serie "tipo liscio"

**223 10601** In scatola con grasso e 2 fascette di serie "tipo liscio" + 2 fascette art.521540 "tipo traforato"

### Kit cuffia elastica per V.W, con grasso e fascette



**223 107** In scatola con grasso e 2 fascette di serie "tipo liscio"

**223 10701** In scatola con grasso e 2 fascette di serie "tipo liscio" + 2 fascette art.521540 "tipo traforato"

Vedi anche pinze fascette 212 017....



### Kit 2 fascette per tutti i tipi di giunti e cuffie servosterzo

Kit 2 pcs clamps for joints



**521 540** Kit 2 fascette  
\*Utilizzabili con cuffie elastiche tipo nostre 223 105

### Attrezzo serraggio fascette a nastro



**223 109** Per fascette mm 5 e mm 8

### Kit fascette a rotolo per giunti omocineticici

Transmission bands set



Vedi anche:  
Cuffie 223 105  
Sez 4

Fascette 521 501  
Sez 15



**223 120** In valigetta  
1 rotolo fascetta mm 5 x mt.50 + 100 fermagli mm 5 + 1 pinza

**223 121** In valigetta  
1 rotolo fascetta mm 5 x mt.50 + 100 fermagli mm 5 + 1 pinza  
1 rotolo fascetta mm 8 x mt.25 + 100 fermagli mm 8 + 1 pinza

#### Ricambi - Spare parts

- 223 111** Pinza per fascette a nastro
- 223 11201** Fascetta con astuccio mm 5 x mt.50
- 223 11301** Fascetta con astuccio mm 8 x mt.25
- 223 11401** Astuccio vuoto per rotoli mm 5 opp mm 8
- 223 115** Confezione 100 fermagli mm 5
- 223 116** Confezione 100 fermagli mm 8

#### Utilizzo - Use



### Attrezzo per fascette a nastro

Tool for circlips



223 111

### Rotolo fascette per serraggio cuffie. Custodia in plastica-fermagli



- 223 112 01 Rotolo con custodia - mm 5x50 mt
- 223 113 01 Rotolo con custodia - mm 8x25 mt
- 223 114 01 Custodia vuota - Per 223 112 e 223 113
- 223 115 Sacchetto Fermagli - mm 5 100 pz.
- 223 116 Sacchetto Fermagli - mm 8 100 pz.

### Attrezzo inserimento corteco differenziale cambio F17 su nuova Cromia e Alfa 15

Tool for differential clutch F17 on Cromia & Alfa 159



223 125

### Chiave ghiera differenziale cambio F17 su nuova Cromia e Alfa 159

Wrench for differential clutch F17 on Cromia & Alfa 159



223 130

### Introduttore cuscinetto differenziale per Alfa 159 1.9 JTD 8V/16V, motore Alfa 1858 bz e 2.2 DDI, Fiat nuova Cromia 8V/16V JTD

Introducer for bearing differential



223 135

### Coppia perni stacco gruppo airbag su volante Fiat

Doblò - Fiorino - Nuova Punto - Qcubo - Idea



230 000

### Set estrattore Air bag Vw

Air-bag removal tool Vw



231 000

Per: Polo - Lupo / New Beetle / Seat / Skoda Fabia - Octavia - Bora AB Bj 1999 / Golf 4 Bj 1998-2004 / Passat B5 - Passat Ab Bj 1997-2000 / Bmw - Mercedes ( Nuovi modelli )

### Estrattore volante di guida

Steering wheel puller

231 001

231 002



231 001

Opel

231 002

Alfa universale - 8x1.25 6x1

### Kit 2 estrattori corto e lungo per volante con air-bag

Special steering wheel puller



Particolare della zampa

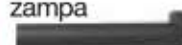

231 004

In valigetta

Apertura Min: 40 mm - Max: 80 mm

Lunghezza vite sottotesta 150 mm

Zampa corta 90 mm - Zampa lunga 140 mm

**Chiave a bussola con inserto Torx 30  
Forato per Airbag VW - Audi**

Wrench socket Torx with hole for Air-bag



mm 300

231 00430 Tx 30 x 300 mm - Att. 1/2"

**Attrezzo a rulli autoserranti interni di nuova esecuzione  
per montaggio / smontaggio braccetti sterzo**



Acciaio



"Universale"

	Serraggio	A	B	C
231 008	Ø 35 - 45	mm 400	Ø 45	Ø 90
231 008 01	Ø 35 - 45	mm 195	Ø 45	Ø 90
231 008 05	Ø 28 - 35	mm 400	Ø 45	Ø 72
231 008 06	Ø 45 - 50	mm 400	Ø 40	Ø 88
231 008 08	Specifico per Daily		New	

**Attrezzo rimozione braccetto sterzo**

Puller for steering arms



231 009	A Ø 20	B Ø 33 - 42
231 00901	A Ø 25	B Ø 39 - 46

**Chiave ghiera servosterzo**

Wrench steering slave nut



231 010 Mercedes 190 - 60x54x8

**Chiave per tensionare cinghia servosterzo**

Wrench for nut pulley of steering slave



231 011 Alfa Romeo - 13 mm

**Chiave ghiera a 4 denti esterni  
per braccetti Daily**

4-tooth external ring nut for Daily arms



231 012

N° denti: 4, Larghezza denti mm 5  
Ø Interno dente / dente mm 31,5  
Ø esterno chiave: mm 38



Made in Italy

**DIGITECH**  
ITALIA

### Chiave ghiera a 4 denti interni per ghiera boccola elastica sospensione anteriore

Wrench for nut front suspension swinging arm bushing



234 212 Daily - Grinta

#### Dati tecnici - Informative

N° denti: 4, Larghezza denti: mm 4

Ø Interno dente/dente: 28 mm x Ø interno chiave mm 32

Ø esterno chiave 40 mm - Lunghezza mm 80 - Att: 1/2"

### Livella telescopica per regolazione volante guida

Extension level for steering wheel regulation



231 015

### Chiave 10 punti femmina per rimozione viti di fissaggio bracci posteriori su Honda CR-V

10 Point impact socket-20mm size: 1/2"DR



231 020 L = mm 38 - M20

### Attrezzo rotazione alberi

Tool for rotation steering arms



231 100 3/8 - 36 mm

231 101 3/8 - 41 mm

### Chiave rotazione alberi



231 103 Apertura Max (A) mm 42

231 107 Apertura Max (A) mm 40 - 47

### Chiave rotazione braccio tirante sterzo

Bar loosening tool



331 010

Universale

### Chiavi smontaggio - serraggio braccetti sterzo



231 125 Att: 3/8" Serraggio mm 13 - 16

231 126 Att: 3/8" Serraggio mm 17 - 22

### Kit estrattore mozzi ruota Auto e Furgoni

Wheel hub puller set



232 000 In valigia

#### Composizione - Composition

1 piastra Ø 90 / 130 mm + 1 piastra Ø 100 / 180 mm

4 tiranti M 12 x 1,25 / 12 x 1,5 / 12 x 1,75 / 14 x 1,5 / 16 x 1,5

4 dadi 18 x 1,5

1 Adattatore 2-1/4"x14UNS x M 18 x 1,5

1 estrattore con massa battente da 4,8 Kg

### Pratico attrezzo per la rotazione del mozzo ruota

Wheel hub holding tool



232 006 Lunga mm 350 In scatola

### Perni per estrazione mozzo per art. 221 032

Pins for hubs for item 221 012



232 007 IM3.



### Ricambi per 232 01020 / 232 01024

232 01025 Campana nuda



232 01026



232 01028 Estrattore a colpo completo di adattatore



232 01029 Adattatore per Vite Ø20 e Estrattore a colpo  
Maschio filetto per vite idraulica - Femmina 20x1,5



232 01030 5 Rondelle per spessore



111 065 Vite 20 x 1.5 x 185



### Estrattore universale in acciaio temprato, per mozzi auto e furgoni

Universal puller in hardened steel



232 01020 Campana + Vite idraulica

232 01021 Campana + Vite idraulica + Adattatore + Vite Ø 20

232 01022 Campana + Adattatore + Estrattore a colpo

232 01023 Campana + Vite idraulica + Adattatore + Estrattore a colpo

232 01024 Estrattore full optional  
Campana+Vite idraulica+Adattatore+Vite Ø20+Estrattore a colpo

### Dati tecnici - Informativa

Campana in Acciaio C45 - HRC 35 - 37.7  
Altezza 90mm x Ø 148mm  
Capacità 116mm / 134mm - 5 / 3 bulloni

Vite idraulica da 12 TON ( Grande forza per sbloccare )

Vite Ø20x1.5x185mm ( Per un'estrazione veloce dopo lo sblocco )

Adattatore Maschio (per filetto vite idraulica) - Femmina 20x1.5

Estrattore a colpo cm 80 x Kg 5 (Incidere grande forza ad ogni colpo)

**Estrattore per mozzi posteriori con ruote gemellate Iveco Daily**



**232 023** Vite 36 x 2 x 200 per ozzi da 8 e 9 fori

**Note:**

**Adattatori opzionali per 232 01050  
Optional adaptors for 232 01050**



**232 010 54** M Ø 16 x 1.5 / F Ø 12 x 1.5 - Pz 5



**232 010 60** F Ø 16 x 1.5 / F Ø 14 x 1.5 - Pz 5

**232 010 61** F Ø 16 x 1.5 / F Ø 16 x 1.5 - Pz 5

**232 010 62** F Ø 16 x 1.5 / F Ø 18 x 1.5 - Pz 5



**232 010 63** M Ø 16 x 1.5 / M Ø 12 x 1.25 - Pz 5

**232 010 64** M Ø 16 x 1.5 / M Ø 12 x 1.75 - Pz 5

**232 010 65** M Ø 16 x 1.5 / M Ø 14 x 1.5 - Pz 5

**232 010 66** M Ø 16 x 1.5 / M Ø 16 x 1.5 - Pz 5

**232 010 67** M Ø 16 x 1.5 / M Ø 18 x 1.5 - Pz 5

**232 010 68** M Ø 16 x 1.5 / M Ø 12 x 1.5 - Pz 5



**232 01070** Maschio / Maschio per: Ford Transit - Pz 5

**Kit estrattore universale per mozzi furgoni, in pratica valigetta metallica**

Universal puller set for van hubs, in practical metal case



**232 01050** Pz.17  
1 Piastra / 1 Vite / 3 serie di colonnette Maschio / femmina

\*Il Kit viene fornito con 3 serie di colonnette:

232 01055 Maschio Ø 16 x 1.5 / Femmina Ø 14 x 1.5 Pz 5

232 01056 Maschio Ø 16 x 1.5 / Femmina Ø 16 x 1.5 Pz 5

232 01057 Maschio Ø 16 x 1.5 / Femmina Ø 18 x 1.5 Pz 5

in alternativa e senza sovrapprezzo possiamo fornirlo con le tre serie di colonnette Maschio - Maschio su vostra indicazione

**Ricambi - Spare parts**



**232 010 51** Piastra



**232 010 52** Vite



**232 010 55** M Ø 16 x 1.5 / F Ø 14 x 1.5 - Pz 5

**232 010 56** M Ø 16 x 1.5 / F Ø 16 x 1.5 - Pz 5

**232 010 57** M Ø 16 x 1.5 / F Ø 18 x 1.5 - Pz 5

**DIGITECH**  
ITALIA

**Kit di spinta per estrazione flangia montante Ford  
In comoda valigetta metallica**



**Ford**  
Ford Transit

**232 010 80** Piastra + 3 colonnette + 5 Perni + 5 Perni - Pz14

Utilizzabile solo in abbinamento con nostro Kit 232 010 50

**Ricambi - Spare-parts**

F14 x 2  M16 x 1.5

**232 010 81** Pz 3

 M16x2

**232 010 82** Pz 5

Spina Ø8  M 10 x 1,5

**232 010 83** Pz 5

**Adattatori opzionali - Optional adaptor**

Spina Ø9  M16 x 2

**232 010 84** Pz 5

**Utilizzo - Using**



**Estrattore smontaggio mozzo posteriore**

Puller of front hubs



**232 016** Alfetta Giulia - Da usare 235 102

**Chiave poligonale per ghiera mozzi posteriori**



**232 018** Att. 1/2" Poligono mm 31  
\*Per Fiat Idea & Lancia Musa

**Chiave Poligonale "CONICA IMPACT" per ghiera mozzi**



**232 019** Att: 3/4" Poligono mm 36  
Mozzo V.W Polo 1.4

**Chiave Esagonale per ghiera mozzi**



**232 029** Att: 3/4" Esagono mm 50

**232 039** Att: 3/4" Esagono mm 39  
\* Indicata per mozzi scooter Yamaha



### Chiave Esagonale "CONICA IMPACT" per ghiera mozzi



**232 020** Att: 3/4" Esagono mm 36  
Chiave conica per ghiera mozzo anteriore

**232 024** Att: 3/4" Esagono mm 41  
Chiave conica per ghiera mozzo Fiat - Ducato

**232 025** Att: 3/4" Esagono mm 42  
Chiave conica per ghiera mozzo anteriore Daily

**232 028** Att.3/4" Esagono mm 46  
\*Ideale per Ducato 2.4

**232 035C** Att.3/4" Esagono mm 35  
\*Ideale per Peugeot gruppo PSA

### Chiave Poligonale "IMPACT" per ghiera mozzi



**232 01831** Att: 3/4" Poligono mm 31  
Mozzo posteriore Fiat Idea e Lancia Musa

**232 025P** Att: 3/4" Poligono mm 43

**232 027** Att: 3/4" Poligono mm 44

**232 033** Att: 3/4" Poligono mm 33  
Mozzo Volkswagen

**232 037** Att.3/4" Poligono mm 37  
Mozzo Volkswagen

**232 039P** Att.3/4" Poligono mm 39  
Mozzo Volkswagen

### Chiave Poligonale per ghiera mozzi



**232 028P** Att.3/4" Poligono mm 46  
\*Ideale per Ducato 2.4

**232 045P** Att.3/4" Poligono mm 45  
Mozzo Ducato

**232 055P** Att.3/4" Poligono mm 55  
Mozzo Ducato (Nuovi modelli)

### Chiave Poligonale "RIBASSATA IMPACT" per ghiera mozzi



**232 02846** Att.3/4" Poligono mm 46  
\*Bussola con Ø esterno ribassato ideale per mozzi posteriori: Jumper, Ducato, Peugeot Boxer

### Chiave Ottagonale per ghiera mozzi



**232 026** Att.3/4" Ottagono mm 50 \*Ideale per mozzo MG

PER BUSSOLE GHIERE "TRUCK" VEDERE SEZIONE 7 DA ARTICOLO 301 041

**DIGITECH**  
ITALIA

### Set 5 pz. chiavi per ghiera mozzi e differenziali

5 pcs. drive tooth socket



232 030 Att. 1/2"

#### Ricambi - Spare parts

- 232 030 01 Ghiera Mercedes Ø42x35 - 4 denti da 6mm
- 232 030 02 Ghiera Mercedes Ø42x35 - 4 denti da 8mm
- 232 030 03 Ghiera Mercedes Ø43x35 - 4 denti conici da 6mm
- 232 03004 Ghiera Mercedes Ø46x38 - 4 denti conici da 6mm
- 232 070 Ghiera Mercedes Ø55x50 - Perno Ø27 - 4 denti da 8mm

### Chiave per ghiera mozzi "4 denti"



Att. 1/2"



Dente



	Att.	Dente	A interno	B esterno
232 031	1/2"	mm 6	mm 30	mm 35

### Chiave ghiera mozzo posteriore ruota singola

232 035  
4 DENTI



232 036  
6 DENTI



232 035 Per ruota singola Transit 64 x 50 x 6

232 036 Per ruota gemellata Transit 67 x 57 x 6

### kit 13 pz per installazione colonnette mozzi ruote

13 pcs wheel stud installer / wheel internal thread tools



232 047

In valigetta

Ideale per modelli Mercedes benz

\* 7/16" x 20 UNF - 1/2" x 20 UNF

\* M 12 x 1.25 - M 12 x 1.5 - M 12 x 1.75 - M 14 x 1.5

Kit filettatura interna: M12 x 1.25, M12 x 1.5, M12 x 1.75, M14 x 1.5

### Set 16 bussole con impronta speciale per dadi mozzi

16 pcs locking nut master key set



Stella 8 punte - Ø est. 7/16"

5 lati - Ø int.5/8"

6 lati - Ø int.41/64"

Esagono scanalato 3 tacche  
Ø est.12 mm

Esagono - Ø 12 mm

7 lati - Ø int.5/8"

7 lati - Ø int.11/16"

7 lati - Ø int.3/4"

6 lati - Ø int.41/64"

Stella 8 punte - Ø est.5/8"

9 punte tipo RIBE - Ø est 13

Stella 10 punte - Ø est.1/2"

Stella 12 punte - Ø int.11/16"

Stella 12 punte - Ø int.13/16"

Esagono - Ø 1/2"

Esagono - Ø 9/16"

232 048

Pz.16 In valigetta

### Set 22 bussole dadi antifurto ideale per BMW



232 049

Att.1/2" Pz.22 In valigetta

## Set 12 bussole dadi antifurto ideale per Mercedes benz

12 pcs special wheel nut socket Mercedes benz



232 04912 Att.1/2" Pz.12 In valigetta

## Kit chiavi maschio per teste viti dadi ruote Bmw

Bmw wheel screw lock socket set

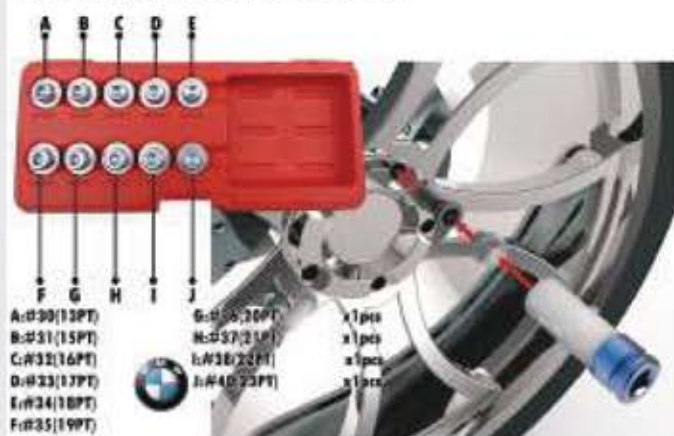

232 052 Pz 10 In valigetta

Contiene

3 Bussole Ø 13,5 con: 13, 15, 16 punte

6 Bussole Ø 15 con: 17, 19, 20, 21, 22, 23 punte

1 Bussola Ø 14 con: 18 punte

\*Utilizzabili con nostra bussola rivestita in teflon Art: 233 022

## Set 23 bussole dadi antifurto ideale per VAG

23 pcs special wheel nut socket for VAG



232 05223 Att.1/2" Pz.23 In valigetta

Composizione - Composition

233 022 Bussola di manovra ricoperta mm 17 x att.1/2"

Bussole Ribe forate: 6, 7, 8, 9, 10, 11, 12, 13, 14, 15, 16, 17

Bussole tipo Xzn: 10, 11, 13, 14, 15, 16, 17, 19, 20, 21 pt

## Kit universale per la rimozione dei dadi ruota danneggiati e dei dadi di sicurezza se si è persa la loro bussola

Universal wheel locking nut removal tool

U  
N  
I  
V  
E  
R  
S  
A  
L



Stop ai problemi con dadi danneggiati!!!

Stop ai problemi dei dadi di sicurezza!!!



Vedi composizione nella Sez 1

161 026

In valigetta

## Set 3 bussole dadi antifurto ideale per BMW

3 pcs special wheel nut socket



232 053 Att.1/2" Su binario

Ricambi - Spare parts

232 05301 10 Punta x Ø 16,0 x L.100 mm

232 05302 17 Punta x Ø 14,5 x L.100 mm

232 05303 21 Punta x Ø 16,5 x L.100 mm

**DIGITECH**  
ITALIA

### Bussola a 5 lati per dadi mozzi di sicurezza Lexus e Toyota

Lexus e Toyota security hub nuts



232 054

Bussola

#### Dati tecnici - Informativa

Bussola a 5 lati x 23 mm

Lunghezza: 100 mm

Attacco 3/8"

Ideale per:

Lexus SUV dal 2005 in poi

Toyota Mini Van & Suv dal 2006 in poi

### Chiave ghiera mozzo anteriore e posteriore

Wrench for front and rear hubs nut



232 055 Lancia Beta - 65 x 58 x 8

232 056 Lancia Gamma - 81 x 72 x 8

### Chiave ghiera mozzo anteriore

Wrench for front hubs nut



232 059 Lancia Flavia-Fulvia u.t. - 50x40x8

### Chiave per ghiera mozzo anteriore

Wrench for front hubs nut



232 060 Per Lancia Flavia e Lancia Fulvia

#### Dati tecnici - Informativa

N° denti: 6, Larghezza denti: 8 mm

Ø esterno chiave 94 x 82 mm

Ø interno chiave 69 mm

Attacco: 3/4"

### Chiave per ghiera mozzi anteriori / posteriori

Wrench for front and rear hubs nut



232 062

#### Dati tecnici - Informativa

N° denti: 6, Larghezza denti: 7 mm

Ø esterno chiave 73 x 61 mm

Ø interno chiave 48,5 mm

Attacco: 3/4"

### Chiave ghiera mozzo anteriore

Wrench for front hubs nut



232 063 Lancia Flavia-Fulvia - 53 x 44 x 6

**DIGITECH**  
ITALIA

### Chiave a ghiera a 6 denti per Porter Piaggio

Wrench for Piaggio Porter



	Att.	A-esterno	B-interno	Dente
232 065 01	1/2"	mm 62	mm 57	mm 7

### Chiave ghiera mozzo posteriore

Wrench for external rear hubs nut



232 066	Lancia Flavia-Fulvia u.t. - 62 x 56 x 12 Per ghiera interna
232 067	Lancia Flavia-Fulvia u.t. - 71 x 62 x 7 Per ghiera esterna
232 068	Lancia Flavia-Fulvia - 71 x 68 x 7 Per ghiera interna
232 069	Lancia Flavia-Fulvia u.t. - 82 x 73 x 7 Per ghiera esterna

### Chiave ghiera per mozzi posteriori Mercedes Benz mod. 107-114-115-116-126

Wrench for posterior hubs



232 070	Att. 1/2" - 4 Denti - Ø55x50x8 - Perno Ø 22
---------	---

### Bussola a 4 perni per dado mozzo anteriore Suzuki Jimmy

Suzuki Jimmy front wheel nut socket



232 071	Att. 1/2" - 4 denti
---------	---------------------

### Chiave ghiera mozzo posteriore



232 072	Alfa 75-164 - 70 x 61 x 7
232 074	Alfetta - 66 x 59 x 7

### Chiave ghiera mozzo posteriore

Wrench for external rear hubs nut



232 075	Regata-Duna weekend - 64 x 56 x 8
---------	-----------------------------------

### Chiave ghiera mozzo posteriore

Wrench for external rear hubs nut



232 080	Polo-Golf - 1/2" - P 30 mm
---------	----------------------------

### Chiave dado mozzo posteriore

Wrench for rear hubs nut



232 082	Tipo - 32 mm
---------	--------------

## Set bussole e maschi impact per ghiere e mozzi

Set impact wrench for hubs nut



232 083 In valigetta

### Composizione - Composition

- 232 08314 Inserto Att.1/2" con Esagono mm 14
- 232 08317 Inserto Att.1/2" con Esagono mm 17
- 232 08319 Inserto Att.1/2" con Esagono mm 19
- 414 52930 Bussola poligonale lunga mm 80 Esagono mm 30
- 414 52932 Bussola poligonale lunga mm 80 Esagono mm 32
- 414 52934 Bussola poligonale lunga mm 80 Esagono mm 34
- 414 52935 Bussola poligonale lunga mm 80 Esagono mm 35
- 414 52936 Bussola poligonale lunga mm 80 Esagono mm 36

## Campana per pulizia mozzi e cerchi Ø esterno 160 mm, Ø interno 60 mm

Wheel hub grinder



232 090 1 campana con 3 pad

### Ricambi - Spare parts

232 091 1 Pad



## Set pulizia base prigionieri su mozzi ruote

Wheel hub grinder



232 09200 In scatola

### Composizione - Composition

- 1 Campana Ø 45 con 6 pad
- 1 Campana Ø 55 con 6 pad
- 1 Adattatore att. 1/2"

### Ricambi - Spare parts

232 093 Pad singolo Ø 55

232 094 Pad singolo Ø 45

## Campana utilizzabile con avvitatore da 1/2" per pulizia mozzi e cerchi. Ø esterno 150 mm, Ø interno 90 mm

Wheel hub grinder



232 095 1 campana con 1 pad

### Ricambi - Spare parts

232 09501 Pad di ricambio



**Campana per pulizia mozzi e cerchi  
Ø esterno 200 mm, Ø interno 82 mm**

Wheel hub grinder



232 096 1 campana con 2 pad

Ricambi - Spare parts

232 097 1 Pad



**Campana per pulizia mozzi e cerchi  
Ø esterno 160 mm, Ø interno 75 mm**

Wheel hub grinder



232 098 1 campana con 3 pad

Ricambi - Spare parts

232 09801 1 Pad



**Innovativa campana per pulizia mozzi, con  
perno centrale per la pulizia del foro mozzo**

Wheel hub grinder

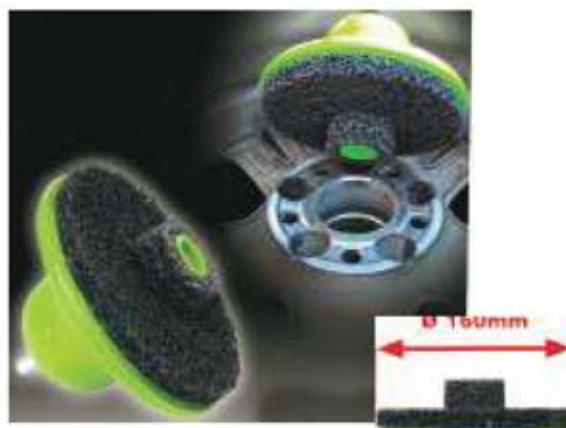

232 099 1 campana con 1 pad

Ricambi - Spare parts

232 09901 1 Pad



**Kit bussole estrazione prigionieri ruote veicoli**

Kit extraction imprisoned car wheels



232 100 Valigetta completa - Pz. 6

Ricambi - Spare-parts

- 232 100 00 Bussola 10 mm
- 232 100 01 Bussola 12 mm
- 232 100 02 Bussola 14 mm
- 232 100 03 Bussola 17 mm
- 232 100 04 Bussola 19 mm
- 232 100 05 Bussola 21 mm.

Vedi anche  
estrattore universale  
161 026 Sez 1



**Kit bussole con filetto passo sinistro per estrazione prigionieri rovinati ruote veicoli**

Damaged nuts remover kit



232 101 Att 1/2" - Pz 7

**Ricambi - Spare-parts**

- 232 101 01 Bussola 1/2" - mm 17
- 232 101 02 Bussola 1/2" - mm 18,5
- 232 101 03 Bussola 1/2" - mm 20
- 232 101 04 Bussola 1/2" - mm 21,5
- 232 101 05 Bussola 1/2" - mm 23
- 232 101 06 Bussola 1/2" - mm 24,5
- 232 101 07 Bussola 1/2" - mm 26

**Kit estrazione dadi rovinati con disegno elecooidale**

Damaged nuts remover kit



232 104 Pz.15 In valigetta

**Ricambi - Spare parts**

- 232 10406 Bussola 1/4" - mm 06
- 232 10408 Bussola 1/4" - mm 08
- 232 10410 Bussola 1/4" - mm 10
- 232 10411 Bussola 1/4" - mm 11
- 232 10412 Bussola 1/4" - mm 12
- 232 10413 Bussola 1/2" - mm 13
- 232 10414 Bussola 1/2" - mm 14
- 232 10415 Bussola 1/2" - mm 15
- 232 10417 Bussola 1/2" - mm 17
- 232 10419 Bussola 1/2" - mm 19
- 232 10421 Bussola 1/2" - mm 21
- 232 10424 Bussola 1/2" - mm 24
- 232 10427 Bussola 1/2" - mm 27

**Set 9 pz. bussole svita dadi rovinati**



232 105 mm 10-11-12-13-14-15-16-17-19 - Att 1/2"

**Kit bussole lunghe con espulsore per dadi rovinati**

Twist socket set

**Acciaio Cr.  
Molibdeno  
Brunito**



mm 150

232 106 Pz 3 - mm 17-19-21 - Att 1/2"

**Kit estrazione mozzi guida Bmw**

Puller for drive shafts



232 115

**Composizione - Composition**

- M 16 x 1,5 - per Subaru
- M 20 x 1,5 - per Vw Beetle - Touareg - Porsche Cayenne
- M 22 x 1,5 - per Bmw E 30 - E 46
- M 24 x 1,5 - per Bmw E36 - Mercedes W203
- M 27 x 1,5 - per Bmw E32 - E34 - E38 - E39 - X5
- M 30 x 1,5 - per Bmw E32 - E34 - E36

**DIGITECH**  
ITALIA



**Attrezzo universale per estrazione dei cuscinetti mozzi con l'utilizzo della pressa**



Brevetto depositato



Per vedere filmato di utilizzo:  
[WWW.AFASUPPORT.IT](http://WWW.AFASUPPORT.IT)

- 232 120 Attrezzo in Alluminio lucido ( in valigetta )
- 232 120 20 Attrezzo in alluminio Anodizzato ( in valigetta )

**Ricambi - Spare-parts**

- 232 120 01 Perno corto per piastra traslante
- 232 120 02 Coppia pemi corti + rondelle + bulloni per prigionieri
- 232 120 03 Coppia pemi medi + rondelle + bulloni per prigionieri
- 232 120 04 Bullone con rondella per blocco piastra traslante

**Attrezzo universale per estrazione dei cuscinetti mozzi dei veicoli commerciali con l'utilizzo della pressa**



Brevetto depositato



- 232 120 50 Attrezzo in Alluminio lucido ( in valigetta )

**Attrezzo estrazione piste cuscinetti**

Universal tool for extraction roller and ball bearing



Per vedere filmato di utilizzo: [WWW.AFASUPPORT.IT](http://WWW.AFASUPPORT.IT) Brevetto depositato

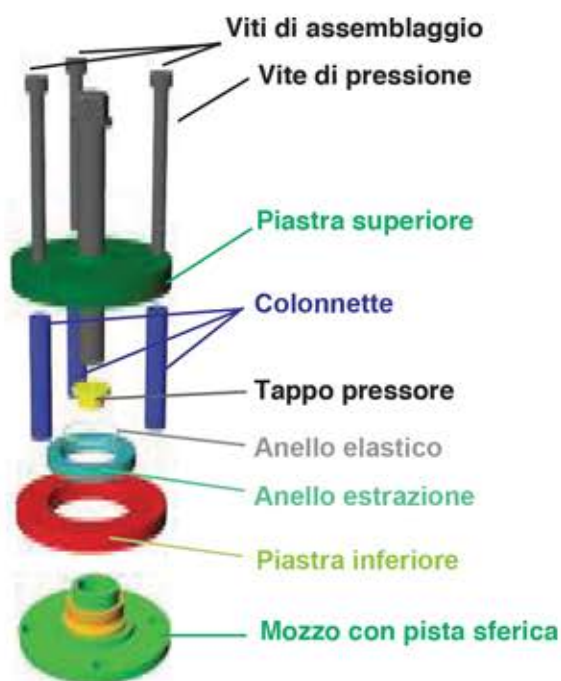

Attrezzo per estrarre in pochi minuti ed in sicurezza tutte le piste dei cuscinetti:

- A sfere ( con o senza cava di schermatura )
- A rulli conici

Grazie alla dotazione di 7 anelli di estrazione di diverso diametro, ognuno dotato di 3 anelli elastici di uguale diametro ma di spessori corda diversi: Ø1,5 - 2 - 2,5 - Simo oltre che di semplice utilizzo, si rende Universale

Risolve un problema annoso per interventi di sostituzione dei cuscinetti sui mozzi

- 232 121 Kit in comoda valigetta termosoffiata.  
Attrezzo + 1 Tappo pressore + 9 anelli di estrazione + 24 anelli elastici

### Anello estrattore

	Ø Esterno	Ø Interno	Spessore
232 121 01	mm 70	mm 38	mm 11 + N° 3 anelli elastici Ø1,5 / Ø2 / Ø2,5
232 121 02	mm 70	mm 42	mm 11 + N° 3 anelli elastici Ø1,5 / Ø2 / Ø2,5
232 121 03	mm 70	mm 45	mm 11 + N° 3 anelli elastici Ø1,5 / Ø2 / Ø2,5
232 121 04	mm 70	mm 47	mm 11 + N° 3 anelli elastici Ø1,5 / Ø2 / Ø2,5
232 121 05	mm 70	mm 49	mm 11 + N° 3 anelli elastici Ø1,5 / Ø2 / Ø2,5
232 121 06	mm 70	mm 52	mm 11 + N° 3 anelli elastici Ø1,5 / Ø2 / Ø2,5
232 121 07	mm 70	mm 54	mm 11 + N° 3 anelli elastici Ø1,5 / Ø2 / Ø2,5
232 121 08	mm 70	mm 57	mm 11 + N° 3 anelli elastici Ø1,5 / Ø2 / Ø2,5
232 121 10			Per mozzo Vw Golf IV serie con ruota fonica + N° 3 anelli elastici Ø1,5 / Ø2 / Ø2,5
232 12112			Vite di ricambio

### Cuffia riparo per montanti ruota

Per lavorare senza sporcarsi e senza respirare polveri tossiche



232 125

### Attrezzo universale per estrazione giunti omocineticici dai semiasi



232 130

In valigetta

### Attrezzo divaricatore per testine sterzo e supporti ammortizzatori, dotato di due cunei separatori intercambiabili



232 135

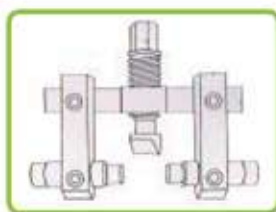

In valigetta

### Attrezzo divaricatore per supporti ammortizzatori e giunti sferici singoli o doppi tipo Audi e Volkswagen

Universal steering knuckle spreader tool



Utilizzo con doppio perno

Utilizzo con singolo perno



232 136 In valigetta

### Torretta di ricambio in plastica per smontagomme, ideale per lo smontaggio gomme dai cerchi in lega



233 001

Torretta

### Ritallonatore "Bazooka"

Aerator auxiliary tank



233 005

Bazooka

### Dati tecnici - Informative

Capacità: 20 lt. - Potenza: 20 Bar - Peso: Kg 14  
Nuovo Ritallonatore MADE IN ITALY, pratico e veloce  
Potente getto d'aria, ritallona all'istante pneumatici di qualsiasi mezzo, dalla moto al mietitrebbia.

### Chiave fissaggio ruota a "croce"

Wrench for wheels nuts



- 233 011** 17 - 19 - 21- 22 mm
- 233 012** quadro 1/2" + 17 - 19 - 21 mm
- 233 015** quadro 3/4" + 24 - 27 - 30 mm

### Pratica pinza per togliere i cappucci dei dadi ruota Particolarmente indicato per i cerchi in lega

Wheel nut cap plier



- 233 017** In blister

### Set chiavi plastificate per bulloni cerchi in lega

Key set plasticized for bolts rims in league



- 233 019** 17-19-21-13/16

### Set 3pz. chiavi con protezione in plastica per cerchi ruote in lega

Plastified wrenches for weels nuts



- 233 020** mm 17 - 19 - 21 In valigetta Pz.3
- 233 021** mm 17 - 19 - 22 In valigetta Pz.3

### Bussola esagonale plastificata per cerchi in lega

Hexagonal plasticized socket wrench



- 233 022** 17 mm Lunga 85 mm
- 233 02217** 17 mm Lunga 150 mm  
Ideale per cerchi in lega con foro profondo
- 233 023** 19 mm Lunga 85 mm
- 233 02319** 19 mm Lunga 150 mm  
Ideale per cerchi in lega con foro profondo
- 233 024** 21 mm Lunga 85 mm
- 233 025** 22 mm Lunga 85 mm
- 233 026** 23 mm Lunga 85 mm
- 233 027** 14 mm Lunga 85 mm
- 233 028** 15 mm Lunga 85 mm  
\*Bussola da mm 15 utilizzabile per cerchi Smart
- 233 029** 13/16" Lunga 85 mm

### Set 3 bussole lunghe per bulloni ruote in lega dei fuoristrda



- 233 030** mm 17 - 19 - 21 x L.150mm Pz.3

### Chiave a bussola impact per viti dadi ruote Mercedes



Att: Lunghezza Impronta

- 233 031** 1/2" mm 50 mm17 \*Mercedes classe S, SL, MML, CS

### Chiave a bussola lunga con teflon per viti dadi ruote

Long plasticized socket wrench



Att: Lunghezza Impronta

**233 03117** 1/2" mm 80 mm 17  
 \*Maybach, W221 & W222 S-class, W216 CL-class, W164 & W166 ML class, W172 SLK class, W221 & W212 & W207 E class, W204 C & GLK class

**233 03121** 1/2" mm 85 mm 21  
 \*Per Hyundai 130, Tucson, Kia

### Bussole dinamometriche

**233 037** Kgm 9 mm 19  
**233 038** Kgm 11 mm 19  
**233 039** Kgm 11 mm 21  
**233 040** Kgm 7,5 mm 19



### Chiave dinamometrica dado fissaggio ruota con quadro maschio da 1/2"

Dinamometric wrench for wheels nuts

1/2"



	Colore	Kg.m
<b>233 051</b>	Verde	9.0
<b>233 052</b>	Nero	10
<b>233 053</b>	Giallo	11
<b>233 054</b>	Rosso	12
<b>233 055</b>	Blu	13
<b>233 056</b>	Arancio	15

### Chiave dinamometrica impact per Truck

Impact dynamometric wrench for truck

Acciaio Cr. Molibdeno -  
 Brunito



	A	B	C
<b>233 070</b>	mm 305 x mm 27	Att.1"	Kgm 45
<b>233 071</b>	mm 305 x mm 30	Att.1"	Kgm 55
<b>233 072</b>	mm 305 x mm 32	Att.1"	Kgm 60
<b>233 073</b>	mm 305 x mm 33	Att.1"	Kgm 65
<b>233 074</b>	mm 305 x mm 34	Att.1"	Kgm 65
<b>233 075</b>	mm 315 x mm 36	Att.1"	Kgm 65

### Pinze per contrappesi cerchi ruota auto

Wheel weight balance pliers



<b>233 091</b>	Senza molla di ritorno	mm 250
<b>233 093</b>	Con molla di ritorno	mm 250

### Pinza brevettata per rimozione pesi adesivi

Wheel weight removal tool.  
 Patented



New



**233 096** Lunghezza 150mmL - Apertura: 10-25mm

#### Dati tecnici - Informative

Ganasce appositamente angolate consentono di prelevare i pesi adesivi dal cerchio senza graffiare la ruota. Non utilizzabile con pesi delle ruote molto ampi

### Attrezzo misurazione inclinazione ruote ant. auto

Tool for checking wheel inclination



- 233 100    Universale - mm 500
- 233 101    Fuoristrada SUV - mm 800

### Attrezzo misurazione convergenza ruote ant.

Tool for checking wheel convergens

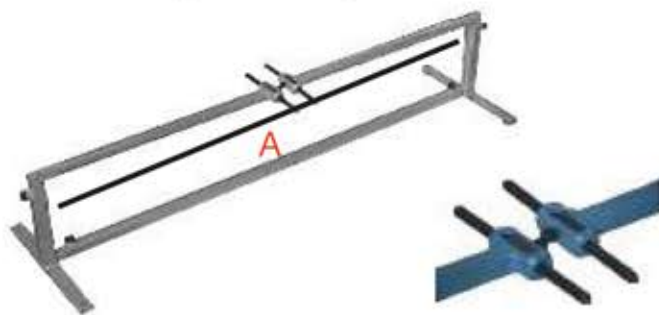

- 233 102    A mm 105    Universale

### Attrezzo misurazione convergenza ruote ant.

Tool for checking wheel convergens

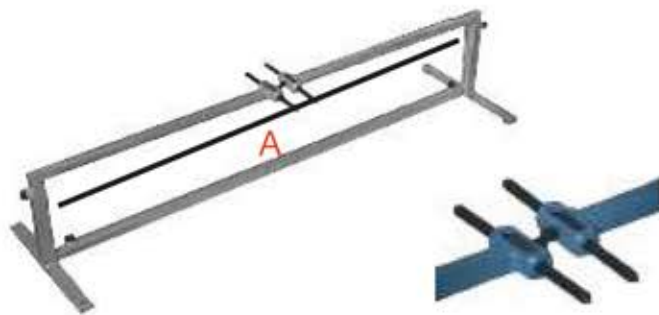

- 233 104    A mm 150    Universale



### Livelle magnetica rilevazione angolo campanatura; range $\pm 5^\circ$ con incrementi di $0.5^\circ$



- 233 110    Con testa fissa    In valigetta
- 233 111    Con testa snodata    In valigetta
- 233 112    Kit 2 livelle in valigetta  
1 Testa snodata + 1 Testa magnetica

### Divaricatore per regolazione angolo di campanatura con due corpi esagonali

Double tool for registration of incidence of front weels



- 233 210    VW Golf Polo

### Contrappesi in Zinco plastificati per equilibratura ruote vetture

Zinc



- |         |          |         |        |
|---------|----------|---------|--------|
| 233 300 | Standard | pz. 100 | gr. 05 |
| 233 301 | Standard | pz. 100 | gr. 10 |
| 233 302 | Standard | pz. 100 | gr. 15 |
| 233 303 | Standard | pz. 100 | gr. 20 |
| 233 304 | Standard | pz. 100 | gr. 25 |
| 233 305 | Standard | pz. 100 | gr. 30 |
| 233 306 | Standard | pz. 50  | gr. 35 |
| 233 307 | Standard | pz. 50  | gr. 40 |
| 233 308 | Standard | pz. 50  | gr. 45 |
| 233 309 | Standard | pz. 50  | gr. 50 |

## Contrappesi in Zinco plasticati per equilibratura ruote vetture

Zinc



233 320	Cerchi in lega	pz. 100	gr. 05
233 321	Cerchi in lega	pz. 100	gr. 10
233 322	Cerchi in lega	pz. 100	gr. 15
233 323	Cerchi in lega	pz. 100	gr. 20
233 324	Cerchi in lega	pz. 100	gr. 25
233 325	Cerchi in lega	pz. 100	gr. 30
233 326	Cerchi in lega	pz. 50	gr. 35
233 327	Cerchi in lega	pz. 50	gr. 40
233 328	Cerchi in lega	pz. 50	gr. 45
233 329	Cerchi in lega	pz. 50	gr. 50

## Pesi in Zinco modello "HOFMANN Type 161" per equilibratura cerchi in ferro

Type 161 with integral clip



233 350	Gr. 5	100 pz.
233 351	Gr. 10	100 pz.
233 352	Gr. 15	100 pz.
233 353	Gr. 20	100 pz.
233 354	Gr. 25	100 pz.
233 355	Gr. 30	100 pz.
233 356	Gr. 35	50 pz.
233 357	Gr. 40	50 pz.
233 358	Gr. 45	50 pz.
233 359	Gr. 50	50 pz.
233 360	Gr. 55	50 pz.
233 361	Gr. 60	50 pz.

## Pesi in Zinco modello "HOFMANN Type 666" per equilibratura cerchi in lega

Type 666 with integral clip



233 370	Gr. 5	100 pz.
233 371	Gr. 10	100 pz.
233 372	Gr. 15	100 pz.
233 373	Gr. 20	100 pz.
233 374	Gr. 25	100 pz.
233 375	Gr. 30	100 pz.
233 376	Gr. 35	50 pz.
233 377	Gr. 40	50 pz.
233 378	Gr. 45	50 pz.
233 379	Gr. 50	50 pz.
233 380	Gr. 55	50 pz.
233 381	Gr. 60	50 pz.

## Contrappesi adesivi tipo "Slim" in Ferro

12x5



4x5 - 4x10



233 396	12 x 5	Gr. 60	Pz 100
233 396 01	4 x 5 + 4 x 10	Gr. 60	Pz 100

## Rotolo contrappesi in ferro per auto



Applicazioni su tutti i cerchi in lega leggera  
Facile da staccare e da applicare  
Larghezza: 19mm x Altezza: 3,5mm  
(incl.nastro adesivo)



233 398 1.000 segmenti da 5 gr. - ( 5 kg )

### Adattatori opzionali - Optional adaptor

Multifunzionale per il montaggio al banco oppure alla parete.  
Pratico metro sul lato esterno con dispositivo di taglio integrato per poter operare in modo rapido e pratico



233 399 Porta-rotolo ( Venduto vuoto )

## Contrappesi adesivi "Hofmann" in zinco per cerchi in lega

Type 390 Zinc adhesive weight for cars



233 410	Gr. 5	100 pz.
233 411	Gr. 10	100 pz.
233 412	Gr. 15	100 pz.
233 413	Gr. 20	100 pz.
233 414	Gr. 25	100 pz.
233 415	Gr. 30	100 pz.
233 416	Gr. 35	50 pz.
233 417	Gr. 40	50 pz.
233 418	Gr. 45	50 pz.
233 419	Gr. 50	50 pz.
233 420	Gr. 55	50 pz.
233 421	Gr. 60	50 pz.

## Protezione cerchi in lega

Alloy wheel rims protection



233 430

In sacchetto

## Valvole tubless SHRADER

Tubless valve



	TR	L	C	pz.
233 601	TR412	33	15	100
233 602	TR413	35	15	100
233 603	TR414	41	15	100
233 605	TR414L	48	15	100
233 607	TR418	54	15	100

## Valvole tubeless snap-in ad alta pressione, indicata per mezzi furgonati: IvecoDaily - Fiat Ducato

High pressure tubeless snap-in valve



233 609 TR 600 - Pz 50

Pressione massima di gonfiaggio a freddo 5,5 BAR

## Tappo valvole

Valve plug



233 610 In plastica - Pz 100

233 611 In metallo - Pz 100

## Valvola in gomma per sensori di monitoraggio della pressione, TPMS, Snap-in

Service valve, TPMS, Snap-in - Schrader 66742-68



Forma della base della valvola

233 612

### Dati tecnici - Informativa

Valvola per velocità fino 210 Km/h  
Schrader 66742-68

## Valvola in gomma per sensori di monitoraggio della pressione, TPMS, Snap-in

Service valve, TPMS, Snap-in - Schrader 66118-68



Forma della base della valvola

233 614

### Dati tecnici - Informativa

Valvola per velocità fino 180 Km/h  
Schrader 66118-68

## Prolunghe per Truck

Extension for Truck



233 617 Prolunga rigida mm 180

233 618 Prolunga flessibile mm 180

233 619 Prolunga curva mm 18 x 37,5

### Introduttore valvole con percussore

Percussion valve introducer



233 620

mm 280

### Valvola interna per valvole pneumatici

Inside valve for valves pneumatic



233 630 Valvola corta . Pz. 100

### Giraviti per smontaggio valvole pneumatici

Tire key dismantling valves

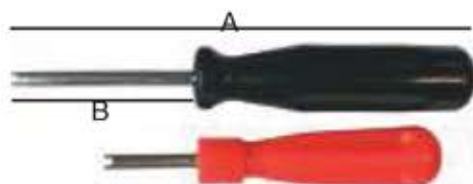

515 455 Modello A.F.A A mm 57 B mm 140

515 457 Modello Import A mm 28 B mm 95

### Utensile montaggio valvole pneumatici

Snap in tire valve installer



515 458

In blister

Vedi anche gonfiagomme  
515 408...Sez 14



**DIGITECH**  
ITALIA

### Kit in valigetta di attrezzi dinamometrici "CERTIFICATI" con accessori per la manutenzione, il montaggio e lo smontaggio di tutti i sensori TPMS

Kit Pressure sensor



\*Unico cricchetto a 90° "certificato"



\*Cacciavite dinamometrico "certificato"



233 720 MADE IN ITALY In valigetta  
\*Taratura chiavi dinamometriche in laboratorio A.F.A

#### Composizione - Composition

233 72014 Cacciavite dinamometrico att."M" da 1/4"  
completo di adattatore porta inserti "F" da 1/4"  
Con certificato 0,5 - 3,0 Nm

233 72015 Chiave a cricchetto dinamometrica a 90°,  
reversibile, att. maschio 1/4"  
Con certificato 3 - 15 Nm

233 72025 Giravite torsionometrico per interno valvola 0,25 Nm

233 72045 Giravite torsionometrico per interno valvola 0,45 Nm

233 72050 Attrezzo introduz./rimoz. guarnizioni valvole TPMS

411 055 Inserto torx att.1/4" x mm 25 Tx 10

411 056 Inserto torx att.1/4" x mm 25 Tx 15

411 057 Inserto torx att.1/4" x mm 25 Tx 20

414 030 Bussola esagonale lunga att.1/4" mm 11

414 031 Bussola esagonale lunga att.1/4" mm 12



### Pezze riparazioni camere d'aria SHRADER

Tube repair patches SHRADER



233 811	Ø 30	Pz 100
233 812	Ø 37	Pz 30
233 813	Ø 45	Pz 30
233 814	Ø 54	Pz 30
233 815	Ø 75	Pz 30
233 817	Ø 116	Pz 30
233 825	Ø 35	Pz 100

### Pezze riparazioni Tubless SHRADER

Tubless repair patches SHRADER



233 835	45 x 45	Pz 50
233 836	60 x 60	Pz 50

### Pezze riparazione pneumatici radiali "SCHRADER"

Repairing tubeless tires patches



233 841	Ø 55 x 75	Box Pz.20
233 842	Ø 70 x 115	Box Pz.10
233 843	Ø 85 x 130	Box Pz.10
233 844	Ø 90 x 75	Box Pz.20
233 84480	Ø 80 x 125	Box Pz.10
233 845	Ø 115 x 125	Box Pz.10
233 846	Ø 100 x 195	Box Pz.10

### Fungo riparazione tubless "SCHRADER"

Repairing tubeless tires tools



233 866	Stelo Ø 3	Box Pz.40
233 86601	Stelo Ø 4,5	Box Pz.40
233 867	Stelo Ø 6	Box Pz.24
233 86708	Stelo Ø 8	Box Pz.12

### Gessetti per marcatura pneumatici



233 874	In box Pz.12
---------	--------------

### Stringhe riparazione pneumatici

Laces reparation pneumatic



233 880	Stringa per vettura - Pz. 60
233 881	Stringa per autocarro - Pz. 30

### Vaselina introduzione stringhe



233 882	gr.50
---------	-------

### Attrezzo riparazione pneumatici

Kit reparation pneumatic

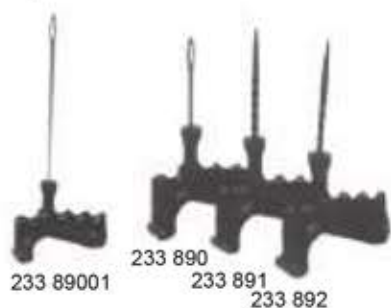

- 233 890 Attrezzo ad ago universale
- 233 890 01 Attrezzo ad ago universale lungo
- 233 891 Attrezzo soluzionatore.
- 233 892 Raspetta per vettura e Truck

### Set riparazione pneumatici



- 233 893 Per vettura
- 233 894 Per Truck

### Ricambi - Spare parts

- 233 880 Stringhe per vetture
- 233 881 Stringhe per truck
- 233 890 Attrezzo ad ago
- 233 892 Raspetta
- 233 89301 Valigetta vuota
- 233 895 Soluzione vulcanizzante 200cc

### Soluzione autovulcanizzante per riparazione pneumatici

Solution autovulcanizzer for reparation pneumatic



- 233 895 200 cc

### Soluzione autovulcanizzante SCHRADER con pennello per riparazione pneumatici

Solution autovulcanizzer SCHRADER for reparation pneumatic



- 233 896 Per camere d'aria - 250 cc - con pennello
- 233 897 Per pneumatici - 250 cc - con pennello
- 233 899 Pennello

### Sigillante per talloni



233 89605

Lt.1

### Pasta montaggio pneumatici

Coil spring compressor



- 233 898 Pasta ad alta resa per vetture Kg,5,5
- 233 89801 Pasta per autocarri Kg,4
- 233 89810 Pasta nera per moto e vettura Kg,5

**DIGITECH**  
ITALIA

### Rigatore elettrico per pneumatici

Electric cutter for pneumatic



233 900 SENZA LAME - 220 V

### Lame ricambio per rigatore elettrico

Sqare blades for electric cutter



- 233 901 01 Lame - R1-3 20 Pz
- 233 901 02 Lame - R2-5 20 Pz
- 233 901 03 Lame - R3-6 20 Pz
- 233 901 04 Lame/ - R4-8 20 Pz
- 233 901 05 Lame - R5-10 20 Pz
- 233 902 01 Lame - W1-3 20 Pz
- 233 902 02 Lame - W2-5 20 Pz
- 233 902 03 Lame - W3-7 20 Pz
- 233 902 04 Lame - W4-9 20 Pz
- 233 902 05 Lame - W5-11 20 Pz

### Misuratore battistrada°

Tread gauge



233 910

### Calibro per il controllo del battistrada pneumatici

Acciaio Inox



	Range mm	Base mm	
233 911	0 - 50	70	In fodera

### Pratiche e potenti presse smonta ammortizzatori professionali

Pneumatic spring compressor

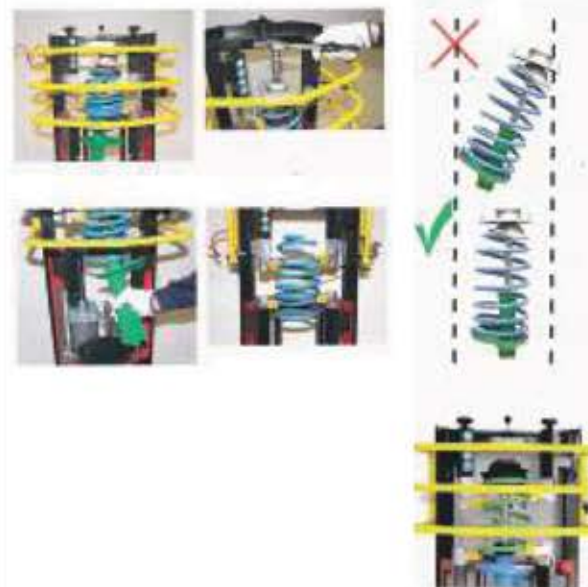

**234 016** Pressa ad 1 pistone  
Min 6 Bar x 735 Kg / Max 10 Bar x 1200 Kg  
Dimensioni: 50 x 40 x 120 cm

**234 01610** Pressa a 2 pistoni  
Min 5 Bar x 1200 Kg / Max 10 Bar x 2400 Kg  
Dimensioni: 50 x 40 x 120 cm

**Compressore per molle sospensione, perno a vite, spalla quadra, telescopico**

Coil spring compressor



234 017 Mercedes

**Attrezzo compressione molle sospensione anteriore**

Front coil spring compressor



234 024 Renault Master

**Attrezzo compressione molle sospensione anteriore**

Front coil spring compressor



234 028 Giulia

**Attrezzo con ganasce variabili per compressione molle ammortizzatori Mc-Pherson**

Spring compressor  
Mc-Pherson



mm 470

234 033

**Attrezzo con 3 coppie di ganasce intercambiabili per compressione molle ammortizzatore**

Interchangeable fork spring compressor and removal

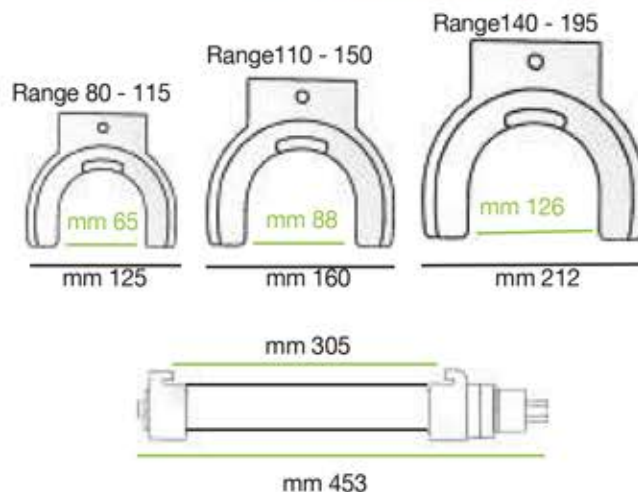

234 035

In valigia

**Ricambi - Spare parts**

234 03501



Vite

234 03502

Staffa porta ganascia

234 03503

Chiocciola vite

234 03504

Quadro di scorrimento

234 03505



Vite interna

234 03506

Ganascia piccola Ø 80 x 115

**DIGITECH**  
ITALIA

### Compressore molle sospensioni

Coil spring compressor



234 040 Universale

### Compressore manuale molle sospensioni

Coil spring compressor



234 043 In scatola

### Compressore molle elicoidali per carichi pesanti

Heavy duty coil spring compressor



234 045 In scatola

#### Dati tecnici - Informative

Capacità: mm 23 - 280

Compressore particolarmente adatto a carichi pesanti



Particolare vite posteriore con esagono di manovra per la regolazione rapida di apertura e chiusura delle ganasce



Particolare tubo telescopico

Particolare tubo filettato per la regolazione finale delle ganasce



### Compressore manuale molle sospensioni con filetto DX / SX con esagono centrale di manovra

Coil spring compressor

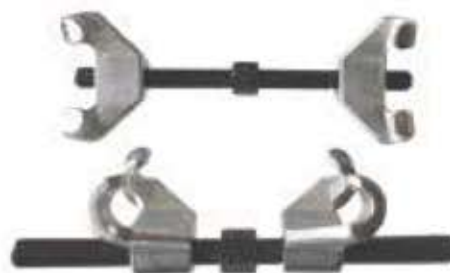

234 048 In scatola

### Compressore manuale molle sospensioni con filetto DX / SX con esagono centrale di manovra

Coil spring compressor



234 049 In scatola

#### Ricambi - Spare parts

234 04901 Vite di ricambio dx / sx 320 mm

#### Adattatori opzionali per Fiat 500



234 04910 Coppia di Viti corte dx / sx 180 mm

### Coppia compressori molle per auto e furgoni, filetto a sezione quadra - ganasce in acciaio forgiato



234 050 Standard - Viti da mm 330

234 050 01 Coppia Viti Ricambio - Su richiesta - mm 260

234 050 02 Coppia Viti Ricambio - mm 320

### Kit compressione molle, con viti filetto DX & SX lunghezza 270 mm e 320 mm

Torque compression springs with thread Dx & Sx



234 052 Max 800 Kg In valigetta

Ricambi - Spare parts

234 05201 Vite di ricambio 270 mm

234 05202 Vite di ricambio 320 mm

### Smonta-ammortizzatori manuale per molloni Mac Pherson

Manual tools Mac pherson Mechanism



Supporto optional  
234 07011

Piastra optional  
234 07010

Base optional  
234 07012

234 070 Smonta ammortizzatori

Dati tecnici - Informative

- Capacità di compressione: 1800 Kg
- Larghezza: 45 Cm
- Profondità: 40 Cm
- Altezza: 118 Cm
- Peso: 47 Kg

### Rubinetto di carica

Exchange charging tap



234 100 Innocenti-Rover

### Set di chiavi smontaggio dado ammortizzatori a bussola foro passante e cricchetto a frizione continua

Set of shock absorber wrenches with ratket



234 130 17-19-21-22-24 mm

Bussole ricambio / Sockets

234 131 17 mm

234 132 19 mm

234 133 21 mm

234 134 22 mm

234 135 24 mm

### Chiave supporto motore lato distribuzione Citroen

Key timing side engine - Citroen



234 160

## Estrattore barra torsione

Suspensions twisting axle



234 200

## Attrezzo rotazione barra di torsione

Torsion bar rotation tool



234 201 Universale Ø 14-23

234 201 40 Universale Ø 40-45

## Estrattore / introduttore Silent block posteriori per Vw Polo

Extraction silent block Vw Polo



234 202 Estrattore

### Ricambi - Spare parts

234 20210 Anello Ø 61 x 10

234 20211 Anello Ø 73.8 x 10

234 20212 Anello Ø 79 x 42

234 20213 Barra filettata con dadi e rondelle

234 20301 Anello Ø 85 x 74

## Estrattore / introduttore Silent block anteriori per Vw Polo

Extractor / inserter Silent block front for VW Polo



234 20220

In valigia

## Estrattore silent block per ponti Fiat Punto



234 203 Completo

### Ricambi - Spare-parts

234 203 01 Anello Ø 85 / 74 mm

234 203 02 Anello Ø 77 / 67 mm

234 203 03 Anello Ø 59 / 44 mm

234 203 04 Anello Ø 73 Sagomato

234 203 05 Anello Ø 62 / 55 mm Alto

234 203 06 Anello Ø 62 / 55 mm Basso

234 203 07 Ranella di pressione

234 203 08 Barra filettata con dadi e ranelle



**DIGITECH**  
ITALIA

## Estrattore / introduttore con pistone idraulico per Silent block montati su ponti posteriori Fiat Stilo e Fiat Bravo

Extraction silent block  
Fiat Stilo & Bravo



Vedi il filmato su:  
[www.afasupport.it](http://www.afasupport.it)



**234 204** Solo attrezzo con 2 pressori e 1 guida

**234 20401** Attrezzo con 2 pressori, 1 guida completo di pompa idraulica manuale 600 bar

**234 20402** Attrezzo con 2 pressori, 1 guida completo di pompa idraulica pneumatica 700 bar

### Ricambi - Spare parts

**234 20403** Pistone idraulico 

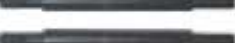
**234 20404** Coppia di tiranti 

**234 20405** Pressore 3 perni 

**234 20406** Pressore a tazza 

**234 20407** Piastra filettata superiore 

**234 20408** Piastra di contrasto inferiore 

**234 20410** Pompa manuale 700 bar completa di tubo e raccordi 

**234 20416** Pompa pneumatica 600 bar completa di tubo e raccordi 

**334 30201** Attacco rapido maschio 700 bar Femmina 1/4" npt 

**334 30202** Attacco rapido femmina 700 bar Maschio 1/4" 

## Adattatore orientabile utilizzabile con nostro attrezzo silent block tramite crick da fossa, ideale per consentire a un solo operatore l'estrazione e l'introduzione



Ø Interno Ø Esterno

**234 20435** 35 45 Adattatore

### Utilizzo - Use

L'adattatore monta di serie un innesto per il pistone del crick di Ø 35, mentre per i pistoni di Ø 22 / 25 / 30 / 40 e Ø 45 sono disponibili una serie di adattatori. Vedi sotto



### Adattatori per cric da fossa



Riduttori Ø Interno per pistoni da: Ø Esterno x 234 20435

**234 20422** Ø 22 Ø 34

**234 20425** Ø 25 Ø 34

**234 20430** Ø 30 Ø 34

Aumentatori Ø Interno per pistoni da: Ø Interno x 234 20435

**234 20440** Ø 40 Ø 46

**234 20445** Ø 45 Ø 46



**Pompa idraulica da 700 bar utilizzabile con nostri:  
234 204 Estrattore Silent block e  
212 13550 Kit idraulico x iniettori**



**234 20410** Pompa 700 bar già raccordata con tubo, nipplo e rapido Maschio

**234 20416** Pompa 600 bar già raccordata con tubo, nipplo e rapido Maschio

**Ricambi - Spare parts**

**234 20414** Pompa da 700 bar "nuda"



**334 30201** Attacco rapido maschio 700 bar Femmina 1/4" npt



**334 30203** Tubo da 700 bar - Mt.2 M.1/4" npt x F.1/4" gir.



**334 30215** Nipplo "Venduto singolo" M.1/4" cil. X M.3/8" cil.



**Adattatori opzionali - Optional**

**334 30202** Attacco rapido F. 700 bar Maschio 1/4" npt



**334 30204** Tappo di chiusura per 334 30202



Made in Italy

**DI GITECH**  
ITALIA

**Piattello in ferro con tampone "Long life" utilizzabile su crick da fossa con pistone Ø 35**

Long life rubber block for crick



	C	D
<b>520 610 10</b>	Ø 35	Ø 45

Il piattello monta di serie un innesto per il pistone del crick di Ø35, mentre i per pistoni di Ø22, Ø25, Ø30, Ø40, Ø 45 come optional a richiesta sono disponibili 5 adattatori



**Estrattore economico a vite per silent block ponte posteriore Fiat Stilo e nuova Bravo**

Extraction silent block Fiat Stilo & Bravo new



**234 204 50** New kit completo

**Ricambi - Spare-parts**

- 234 204 51** Anello tubo a Ø85x68x140
- 234 204 52** Anello tubo b Ø85x67x30
- 234 204 53** Anello pieno c Ø57,3x50
- 234 204 54** Anello pieno d Ø85x30
- 234 204 55** Anello pieno e Ø85 3perni
- 234 204 56** Barra filett.acc.b7 m12x350
- 234 204 57** Cusc.reg/spinta cad.

## Estrattore / introduttore Silent block su Panda natural power metano 4 x 4

Extraction silent block Fiat Panda natural power 4 x 4



234 20470 In valigetta

### Ricambi - Spare parts

234 20471	Perno reazione Ø 30X165
234 20472	Boccola Ø 32X64-44,4
234 20473	Boccola fresata Ø 60X20
234 20474	Boccola Ø 60X20
234 20475	Coppia cuscinetti reggi spinta
234 20476	Coppia bicchierini per cuscinetti
234 20477	Vite M12x210
234 20478	Dadi M12X20
234 20480	Vite completa

### Utilizzo - Use

Introduzione



Estrazione



## Attrezzo montaggio boccole elastiche sospensione anteriore

Tool front suspension swinging arm bushing



234 211 Daily-Grinta

## Estrattore / introduttore Silent block Fiat 500/595 Abarth

Extraction silent block Fiat 500/595 Abarth



234 20490 Estrattore

### Ricambi - Spare parts

234 20475	Coppia cuscinetti reggi spinta
234 20476	Coppia bicchierini per cuscinetti
234 20478	Dadi M 12 x 20
234 20491	Boccola estrattore Ø 70-60.5x67
234 20492	Boccola estrattore Ø 57-41x27
234 20493	Boccola guida Ø 50.5-41x23
234 20494	Vite M 12x250
234 20495	Vite completa

## Estrattore silent block, Bmw - Mini Cooper

Silent block tool set, Bmw - Mini



234 208 In valigetta

### Dati tecnici - Informative

1 Series: E81, E87  
 3 Series: E36, E46, E83, E90, E91, E92, E93  
 5 Series: E39, E60, E61, E70  
 6 Series: E63, E64  
 7 Series: E38, E65, E66, E67  
 8 Series: E31, E52  
 Z4: E85, E86  
 MINI COOPER S: R53

## Chiave a 4 denti per ghiera boccola elastica sospensione anteriore

Wrench for nut front suspension swinging arm bushing



234 212 DAILY - GRINTA

### Dati tecnici - Informative

N° denti: 4 , Larghezza denti: mm 4

Ø Interno dente/dente: 28 mm x Ø interno chiave mm 32

Ø esterno chiave 40 mm - Lunghezza mm 80 - Att: 1/2"

### Note:

## Kit in valigetta per estrazione / inserimento Cuscinetti, Silentblock, Boccole

Press on sleeve kit



234 219 Kit universale in valigia rigida Pz. 26

### Ricambi - Spare parts

234 21901 Vite nuda Ø 10

234 21902 Vite nuda Ø 12

234 21904 Vite nuda Ø 14

234 21906 Vite nuda Ø 16

234 21910 Vite + cuscinetto M 10

234 21912 Vite + cuscinetto M 12

234 21914 Vite + cuscinetto M 14

234 21916 Vite + cuscinetto M 16

234 21920 Piattello

### Composizione - Composition



2 piattelli con due facce (A & B) ognuno

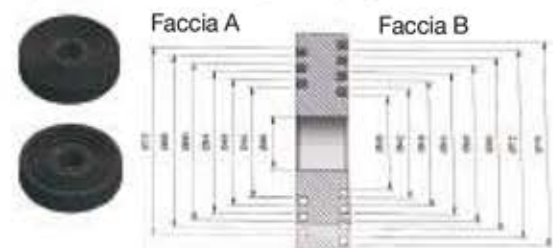

**Kit idraulico per estrazione boccole, con capacità di spinta pari a 12 Ton.**



**234 220** In trolley Kg.31

**Composizione - Composition**

- Fila 1 - 28x20 - 32x24 - 36x28 - 40x32 - 44x36 - 48x40 - 50x42 - 52x44 - 56x48 - 60x52 - 64x56 - 68x60 (Altezza mm 40)
- Fila 2 - 68x60 - 64x56 - 60x52 - 56x48 - 52x44 - 48x40 - 44x38 - 42x34 - 40x32 - 38x28 - 32x24 - 28x20 (Altezza mm 110)
- Fila 3 - 66x58 - 62x54 - 58x50 - 54x46 - 50x42 - 46x38 - 38x30 - 34x26 - 30x22 - 26x18 (Altezza mm 110)
- Fila 4 - 26x18 - 30x22 - 34x26 - 38x30 - 42x34 - 46x38 - 54x46 - 58x50 - 62x54 - 66x58 (Altezza mm 40)

**Ricambi - Spare parts**

- 234 22010** Vite Maschio Ø10 x 450mm
- 234 22012** Vite Maschio Ø12 x 450mm
- 234 22014** Vite Maschio Ø14 x 450mm
- 234 22016** Vite Maschio Ø16 x 450mm

**Kit estrattore boccole idraulico con capacità di spinta pari a 12 Ton. - In trolley -**

Hidraulic 12 ton. steering sistem pull toll set - In trolley



**234 221** Universale - Trolley Kg 31

**Composizione - Composition**

- Fila 1 - 28x20 - 32x24 - 36x28 - 40x32 - 44x36 - 48x40 - 50x42 - 52x44 - 56x48 - 60x52 - 64x56 - 68x60 (Altezza mm 40)
- Fila 2 - 68x60 - 64x56 - 60x52 - 56x48 - 52x44 - 48x40 - 44x38 - 42x34 - 40x32 - 38x28 - 32x24 - 28x20 (Altezza mm 110)
- Fila 3 - 66x58 - 62x54 - 58x50 - 54x46 - 50x42 - 46x38 - 38x30 - 34x26 - 30x22 - 26x18 (Altezza mm 110)
- Fila 4 - 26x18 - 30x22 - 34x26 - 38x30 - 42x34 - 46x38 - 54x46 - 58x50 - 62x54 - 66x58 (Altezza mm 40)

**Ricambi - Spere parts**

- 234 22110** Staffa
- 234 22111** Pistone idraulico

### Kit per estrazione inserimento cuscinetti del gruppo - VAG

Wheel hub / wheel bearing tool set

utilizzabile su  
veicolo / pressa



234 250 Pz 15

#### Dati tecnici - Informativa

- Audi A2 dal 2000 / Skoda Fabia dal 2000
- Vw Polo dal 2002 / Seat Ibiza dal 2000
- Fox dal 2005

### Spurgafreni e frizioni a membrana



Terza camera di riserva per più operazioni a pressione costante dotata di due taniche recupero olio e imbuto di riempimento. Senza tappi in dotazione.

234 907

Capacità olio (camera superiore) - 5 Litri -  
Max bar utilizzo (camera centrale) - 2 bar  
Max bar riserva (camera inferiore) - 10 bar -  
Lunghezza tubo erogazione - 3 Mt  
Valvola di sicurezza - 10 bar

### Spurgafreni e frizioni a membrana



Terza camera di riserva per più operazioni a pressione costante dotata di due taniche recupero olio e imbuto di riempimento. Dotazione tappi standard.

234 908

Capacità olio (camera superiore) - 5 Litri  
Max bar utilizzo (camera centrale) - 2 bar  
Max bar riserva (camera inferiore) - 10 bar  
Lunghezza tubo erogazione - 3 Mt  
Valvola di sicurezza - 10 bar

### Serie tappi standard composta da 5 tappi a vite (A-D-F-I-T) ed un tappo universale (W)

Tool rear suspension swinging arm busching



234 909

### Tanichetta recupero olio freni



234 910 Tanichetta

234 910 01 Tubo di ricambio

### Serie tappi extra a vite (B-C-E-G-H-K-L-M-P-R-U-X-Y-Z)



234 911

**DIGITECH**  
ITALIA

## Tappi per radiatori



**234 91101** Tappo singolo ( A )  
**Per vetture:** Alfa, Austin morris, Ferrari, Fiat, Ford, Innocenti, Leyland, Rover, Vauxall  
**Per Truck:** Bedford, Fiat

**234 91102** Tappo singolo ( B )  
**Per vetture:** Autobianchil, Fiat  
**Per Truck:** Fiat.

**234 91103** Tappo singolo ( C )  
**Per vetture:** Autobianchi, Lafer, Porsche, Volkswagen

**234 91104** Tappo singolo ( D )  
**Per vetture:** Alfa, Austin morris, Bmw, Citroen, Daf, Ferrari, Ford, Innocenti, Lamborghini, Lancia, Maserati, Matra, Mercedes, Nsu, Opel, Peugeot, Porsche, Renault, Saab, Seat, Talbot, Vw, Volvo  
**Per Truck:** Beerliet, Daf, Fiat, Ford, Mercedes, Renault, Scania

**234 91105** Tappo singolo ( E )  
**Per vetture:** Citroen

**234 91106** Tappo singolo ( F )  
**Per vetture:** Opel, Peugeot, Talbot,  
**Per Truck:** Beerliet, Ebro, Fiat, Pegaso comet, Renault, Unic

**234 91107** Tappo singolo ( G )  
**Per vetture:** Ferrari, Maserati, Renault, Volvo  
**Per Truck:** Bedford, Ford, Scania

**234 91108** Tappo singolo ( H )  
**Per vetture:** Autobianchi, Ferrari, Fiat, Lamborghini, Lada, Seat  
**Per Truck:** Astra, Fiat, Unic

**234 91109** Tappo singolo ( I )  
**Per vetture:** Citroen, Fiat, Renault  
**Per Truck:** Ebro, Fiat, Renault, Saviem, Unic

**234 91110** Tappo singolo ( K )  
**Per vetture:** Mitsubishi

**234 91111** Tappo singolo ( L )  
**Per vetture:** Alfa, Innocenti, Jaguar  
**Per Truck:** Bedford

**234 91112** Tappo singolo ( M )  
**Per vetture:** Maserati, Peugeot, Renault  
**Per Truck:** Bedford

**234 91113** Tappo singolo ( T )  
**Per vetture:** Austin morris, Ford, Lend rover, Triump  
**Per Truck:** Berliet

**234 91114** Tappo singolo ( U )  
**Per vetture:** Mitsubischi

**234 91115** Tappo singolo ( W )  
**Per vetture:** Bmw, Lamborghini, Lancia, Land rover, Mazda, Nissan, Toyota

**234 91116** Tappo singolo ( P )  
**Per Truck:** Fiat, Unic

**234 91117** Tappo singolo ( R )  
**Per Truck:** Volvo

**234 91118** Tappo singolo ( X )  
**Per Truck:** Bedford, Pegaso comet, Saviem

**234 91119** Tappo singolo ( Z )  
**Per Truck:** Beerliet, Renault, Saviem

## Spurgafreni pneumatico e spurgafreni pneumatico con kit per pratico riempimento filtro gasolio

Filling fuel filter and bleed pneumatic brakes



**235 045** Spurgafreni pneumatico Lt.2

**235 046** Kit Spurgafreni pneumatico Lt.2 completo di kit riempimento filtro gasolio

Ricambi per 235 045 e 235 046

**235 041**  Pipetta

**235 04501**  Attacco con pipetta

**235 04512**  Filtrino di ricambio per 235 045 e 046

**235 04600** Kit di tubi Ø6 e Ø8 con attacco rapido e con raccordi Ø9 e Ø9,5

**235 04601** Tubo Ø 6 con attacco rapido

**235 04602** Tubo Ø 8 con attacco rapido

**235 04603** Raccordo porta gomma Ø 9

**235 04604** Raccordo porta gomma Ø 9,5

## Kit su guida bussole triangolari per freni



**212 323** M5, M6, M8, M10, M12

\*M6 indicata per regolatori pompa iniezione VAG - Tdi

### Kit di 5 chiavi per spurgo freni

5 pcs brake bleeder wrench with check valve



**235 050** In valigetta 5  
chiavi misure: 8,9,10,11,12 mm  
1 tubo di scarico con valvola di ritorno

#### Adattatori opzionali - Optional

**235 05007** Chiave singola mm 7

#### Dati tecnici - Informative

Ideale per sfiatare il sistema frenante e il sistema idraulico della frizione  
Non serve rimuovere le ruote  
Non serve rimuovere la chiave per effettuare lo spurgo, perchè l'olio passa all'interno della bussola

### Chiavi per raccordi tubetti freno

Wrench for operating on brake connectors



<b>235 057</b>	Chiave piegata	mm 10
<b>235 058</b>	Chiave piegata	mm 11
<b>235 059</b>	Chiave piegata	mm 12
<b>235 061</b>	Chiave piegata	mm 14
<b>235 065</b>	Chiave doppia dritta	mm 8 x 9

### Chiave fissa aperta esagonale dadi di raccordo tubazioni

Flare nut wrench for pipe fittings

**Crom Vanadium**  
**Cromata**



<b>413 461</b>	8x10 mm
<b>413 462</b>	10x11 mm
<b>413 463</b>	10x12 mm
<b>413 464</b>	11x13 mm
<b>413 465</b>	12x14 mm
<b>413 466</b>	13x14 mm
<b>413 467</b>	14x17 mm
<b>413 468</b>	16x18 mm
<b>413 469</b>	17x19 mm

### Chiave da 11 fissa e snodata per condotti freni con molla apri e chiudi brevettata

Brake pipe wrench



**235 070** mm 11

### Chiave registro freni

Wrench adjusting brakes



**235 076** Mini Minor

### Chiave registro freni

Wrench adjusting brakes



**235 077** Simca 1000

### Chiave registro freni

Wrench adjusting brakes



**235 078** Citroen GS

### Chiave registro freni

Wrench adjusting brakes



**235 079** Alfa Sud - 17 mm

### Chiave registro freni

Wrench adjusting brakes



**235 080** Fiat - 17 mm

### Chiave registro freni - Pentagonale M 10

Wrench adjusting brakes



**235 081** Att. 1/2" Renault-Peugeot-Citroen

### Chiave registro freni

Wrench adjusting brakes



235 082 Renault-Peugeot-Citroen - Penta

### Chiave registro freni

Wrench adjusting brakes



235 083 Renault - 10 mm

### Chiave registro freni

Wrench adjusting brakes



235 084 Renault - 10 mm

### Set 6 chiavi raccordi tubi freno

6pcs brake bleeder wrench



235 085 In valigetta

#### Composizione - Composition

Chiave:	Esagono aperto 5/16"	Quadro 1/4"
Chiave:	Esagono aperto 7/16"	Quadro 11/32"
Chiave:	Quadro 1/4"	Quadro mm 10
Chiave:	Esagono 1/4"	Esagono mm 7
Chiave:	Esagono mm 8	Esagono mm 10
Chiave:	Esagono mm 9	Esagono mm 11

### Pinza piegatura tubetti freno sostegno durante il taglio o il montaggio

Plier for aid brake connectors



235 090 4,75 mm

### Atrezzo montaggio molle ganasce freni posteriori al porta ceppi

Tool for refitting brake shoe retaining spring



235 091 Fiat

### Estrattore tamburi freni

Puller brake drums B mm

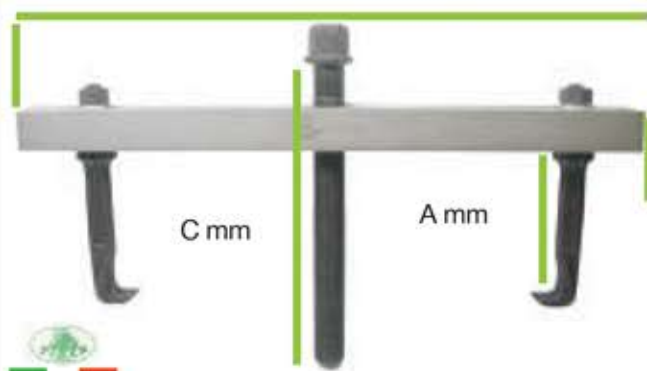

235 103

Estrattore

#### Ricambi - Spare parts

235 10301 Traversa ( B 380 mm )

111 123 Zampa ( A 95 mm )

111 065 Vite ( C 185 mm )

#### Adattatori - Optional adaptors



111 03301 Prolunga optional singola - 100 mm

### Estrattore tamburi freno

Puller for flange axle



235 104 Diametro max 120 mm

### Estrattore tamburi freno

Puller for flange axle



235 105 FIAT



### Estrattore tamburi freno con zampe regolabili

Puller for flange axle



235 106 Universale

### Attrezzo arretramento pistoncini freno

Equip withdrawal piston brake



235 112

### Attrezzo di grande sforzo indicato per divaricamento cilindretti freno

Disc brake piston compressor

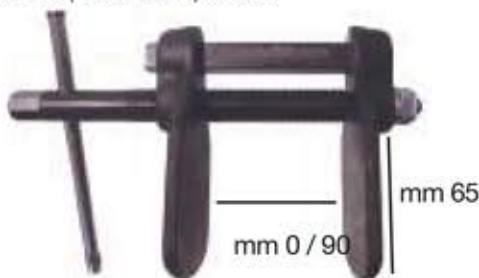

235 113

In scatola

### Arretratore pistoncini freni att. quadro 1/4" con rotazione DESTRA e SINISTRA. Inclusive nel kit 2 pratiche pastiglie a 2 & 3 spine con Ø regolabile da 20 a 35 mm

2 & 3 pin brake wind back tool right & left spanner



Calzare l'anello con interno esagonale alla pastiglia, per ottenere la rotazione libera destra e sinistra

235 115

In valigetta

### Arretratore pistoncini freni con rotazione DESTRA e SINISTRA, utilizzabile sia con pastiglie con attacco quadro 3/8", sia con pastiglie con attacco a 2 fori. Semplifica le operazioni di lavoro grazie al suo pratico sistema a molla interno.

3/8" Dr. brake caliper piston rewind tool



235 116

In blister

### Attrezzo rotazione pistoncini freno

Tool for rotating brake disc piston



235 123

Renault

### Attrezzo rotazione pistoncini freno

Tool for rotating brake disc piston



235 124

Bravo-Coupè-Barchetta-Kappa

### Attrezzo rotazione pistoncini freno

Tool for rotating brake disc piston



235 130

Universale - 3/8"

### Set bussole pentagonali per pinze freni. Att.1/2"

3 pcs 1/2" pentagon socket



1/2"

235 134 Pz. 3 In valigetta

#### Ricambi - Spare-parts

		A	B
235 081	Pentagono maschio	mm 10	mm 7
235 135	Pentagono femmina	mm 14	mm 10
235 136	Pentagono femmina	mm 19	mm 1/2"

### Set rotazione pistoncini freno Dx / Sx



235 137 Kit in valigetta senza presa rapida

235 137 05 Kit in valigetta con presa rapida

#### Ricambi - Spare-parts

235 137 01 Solo pistola senza presa rapida

235 137 06 Solo pistola con presa rapida

235 137 07 Solo adattatore 2 pemi

235 137 08 Solo adattatore □ 3 / 8

#### Adattatori opzionali - Optional adaptor



Adattatore ribassato intercambiabile con nostro attrezzo pneumatico per rotazione pistoncini freni a disco, da utilizzare in presenza di pastiglie usurate  
Adaptor for pneumatic piston brake

235 137 40



### Pressore per cilindretti freno



235 137 20 Ford Focus / C-Max - Attacco 2 fori

### Pressori cilindretti freno di ricambio per kit rotazione pistoncini freno Art: 235 137



235 13721 Pastiglia "A" Ø30 con 2 spine Ø 4

235 13722 Pastiglia "F" Ø32 con 2 spine Ø 4

235 13723 Pastiglia "E" Ø42 con 4 spine Ø 5

235 13725 Pastiglia "M" Ø32 con 2 spine Ø 5,5

235 13726 Pastiglia "N" Ø32 con esagono calamitato Ø12

235 13727 Pastiglia "K" Ø54 con 2 spine Ø8 e perno centrale Ø11,5

### Pressore per cilindretti freno Ford (USA) - Lincoln - Subaru



235 13730 Pastiglia "B" Ø38 con 2 spine Ø 10

### Pressore cilindretti freno per nuove Renault



235 13742 Ø 35 con 3 spine Ø 4mm

## Pressore per cilindretti freno



235 13745 Ø 42 con 3 inserti fresati mm 3,5x6  
Per nuove Audi

235 13750 Iveco Daily - Attacco 2 fori

235 13752 Ø 28mm con 4 perni da 5mm Per Mini

## Set rotazione pistoncini freno per auto giapponesi ed europee e USA

Kit rotation brake pistons for Japanese, EU and USA cars



235 138 Con attrezzo per rotazione destra

235 139 Con attrezzi per rotazione destra e sinistra

### Ricambi - Spare parts



235 139 Dx "Destro"

235 139 Sx "Sinistro"

## Set rotazione pistoncini freni destro



235 140

In valigetta

## Set rotazione pistoncini freno destro e sinistro con perno centrale sfilabile in caso di blocco attrezzo



235 140 10

In valigetta

12 Pz

### Composizione - Composition

235 141 Estrattore completo destro - 3/8

235 141 01 Estrattore completo sinistro - 3/8

235 142 Esagono - 12 mm

235 143 Diam 31.5 - 2 perni diam 5 mm  
Interasse 21 mm

235 145 Diam 41 - 2 perni diam 6 mm  
Interasse 34 mm

235 146 Diam 44 - 2 perni diam 6 mm  
Interasse 33 mm

235 148 Snodo Diam 66 - diam interno 33 mm 44 mm

235 149 Piastrina

235 150 Diam 36 - Fiat Stilo e Multipla

235 15001 Pressore per Renault Laguna

235 15006 Pressore per Ford Focus

235 151 Diam 45 - Fiat Ducato

235 153 Diam 28 - Alfa Romeo - Audi - Volkswagen

235 15401 Piattello per ultime BMW serie 3 e 5

## Ghiera per arretramento pistoncini freni

Ferrule for withdrawal little pistons you brake



235 150 Fiat Stilo - Ø36

### Pressore per cilindretti freno per Renault Laguna

Ferrule for withdrawal little pistons you brake



235 150 01 Attacco - 3/8"

### Pressore per cilindretti freno per Audi 100

Ferrule for withdrawal little pistons you brake



235 150 02 Attacco - 3/8"

### Pressore per cilindretti freno per Citroen BX

Ferrule for withdrawal little pistons you brake



235 150 03 Attacco - 3/8"

### Pressore per cilindretti freno per Citroen C 5 - C 6



235 150 04 C 5 - Cilindretto destro - Attacco - 3/8"

235 150 05 C 6 - Cilindretto sinistro - Attacco - 3/8"

### Pressore per cilindretti freno per Ford Focus



235 150 06 Attacco - 3/8"

### Pressore per cilindretti freno per Nissan



235 150 07 Attacco - 3/8"

### Pressore per cilindretti freno per Subaru



235 150 08 Attacco - 3/8"

### Pressore 3 denti per cilindretti freni Ford



Utilizzabile con  
art. 235 14010



235 150 20 Attacco - 3/8"

### Ghiera per arretramento pistoncini freni

Ferrule for withdrawal little pistons you brake



235 151 Daily - Ø45

### Ghiera per arretramento pistoncini freni

Ferrule for withdrawal little pistons you brake



235 153 Alfa Romeo - Audi - VW - Ø28

### Nuovi piattelli per 235 140 e 235 14010 per vetture BMW



235 154 01 BMW serie 3 e 5 ultimo tipo

235 154 02 Mini By BMW

235 154 03 BMW 1° serie

### Chiave per ghiera anello di comando freni

Wrench for adjusting brakes nuts



235 158 Audi - 28 x 18 x 4

### Bussola per la rimozione delle viti di fissaggio sulla pinza freno - Audi S5

Special socket for caliper Audi S5



235 159 7 Punta x 22 mm Audi S5

### Chiave pinza freni, 10 punte

Special Brake caliper socket



235 160 10 punte x 9 mm  
\*Ideale per Porsche, VW Touareg, Audi Q7

### Chiave pinza freni, 10 punte

Special Brake caliper socket



235 16011 10 punte x 11,5 mm  
\* Ideale per Porsche, VW Touareg, Audi Q7

235 16015 10 punte x 15 mm  
\* Ideale per Audi A8, S6 / Porsche Cayenne

235 16020 10 punte x 20 mm  
\* Ideale per Audi A8, S6 / Porsche Cayenne

### Bussola speciale per pinza freni Audi Q7

Special brake caliper socket for Audi S4



235 16007 7 Punta x 14 mm Per Audi Q7

### Chiave per montaggio pinze freni

Wrench for refitting disc brake



235 161 Peugeot-Renault-Citroen - 5 lati 19 mm

### Attrezzo per ceppi freno

Tool for brakes



235 165 Universale

### Attrezzo doppio per molle ceppi freno

Tool double for dampers

con cappuccio antinfortunistico



235 167 Universale

### Attrezzo per molle ceppi freno

Tool for dampers



235 168 Universale

### Chiave a bussola pinze freni Audi e Volkswagen



235 169 Bussola con inserto XZN forato M 14

235 16914 Bussola monolitica XZN forato M 14

### Pinza molle freni

Plier for refitting dampers



235 170 Universale - 220 mm

### Pinza molle freni a tamburo

Plier for refitting dampers



235 174 Universale - 320 mm

### Pinza molle freni con estrattore tenuta molle

Plier for refitting dampers



235 176 Universale - 330 mm

Note:

### Pinza per molle ganasce freni a tamburo

Plier for brake hubs spring

Made in Germany



235 182 mm 230

Note:

### Pinza per molle freni autocarro

Brake spring pliers



235 185 mm 540

235 185 01 Gancio di ricambio

**DIGITECH**  
ITALIA

**Kit per il ripristino filetti freni a disco  
V.A.G / Opel / Ford**



**235 195** In valigetta

**Ricambi - Spare parts**

**235 19501** Filetti con rondella Pz.10  
In sacchetto



**Chiave regolazione freni Audi, Penta Tx - forata**



**235 286** Att. 3/8" B Ts 55 C mm 48

**Pratico kit per svasare tubetti freni in rame  
di vari diametri, 4,75 mm, 5 mm, 6 mm**

Brake flaring tool set



**235 210** In valigetta

**Chiave per regolazione freni**



**235 288** Att. "1/2" - Esagono 11 X 120 mm  
Per MERCEDES

**414 73109** Att. "1/2" - Esagono 9 X 100 mm  
Per BMW e VW

**Set montaggio / smontaggio freni**

High quality brake tool set



**236 000**

Contiene: Pinze per molle freni - Pinza per cavo freno a mano - 2 spazzole - Perni per rimuovere lo sporco - Utensili per molle freni a mano - Utensili per molle freni a tamburo - Cacciavite a snodo - Chiave per tubetti freni. Chiave registro freni.

**DIGITECH**  
ITALIA

