

VEDI ANCHE BUSSOLE SEZIONE 9

### Chiavi a bussola Poligonali

Poligonal impact socket wrench



1" Acc. Cr.V

301 046	Att 1"	46 mm
301 047	Att 1"	47 mm
301 050	Att 1"	50 mm
301 052	Att 1"	52 mm
301 054	Att 1"	54 mm
301 055	Att 1"	55 mm
301 057	Att 1" - Ford Transit	2" 1/4
301 058	Att 1"	58 mm
301 060	Att 1"	60 mm
301 063	Att 1"	63 mm
301 065	Att 1" - Mozzi Daily	65 mm
301 070	Att 1"	70 mm
301 075	Att 1"	75 mm
301 080	Att 1"	80 mm

### Chiavi a bussola Esagonali



1" Acc. Cr.V

301 110	Att 1"	mm 46
301 112	Att 1"	mm 48
301 114	Att 1"	mm 50
301 116	Att 1"	mm 52
301 118	Att 1"	mm 54
301 119	Att 1"	mm 55
301 120	Att 1"	mm 58
301 122	Att 1"	mm 60
301 123	Att 1"	mm 63
301 125	Att 1"	mm 65
301 128	Att 1"	mm 70
301 131	Att 1"	mm 75
301 134	Att 1"	mm 80

### Chiavi a bussola Esagonali impact "extra lunga"

Hexagonal impact socket wrench "extra long"



1" Acc. Fosfatato

	Att"	Lunghezza	Esagono
302 05516	1"	mm 160	mm 55
302 06020	1"	mm 200	mm 60
302 06520	1"	mm 200	mm 65
302 07020	1"	mm 200	mm 70
302 07520	1"	mm 200	mm 75
302 09520	1"	mm 200	mm 95

### Chiavi a bussola Esagonali

Hexagonal impact socket wrench



1" Acc. Fosfatato

302 060	60 mm	302 094	94 mm
302 062	62 mm	302 095	95 mm
302 063	63 mm	302 09526	95 X H°126mm
302 065	65 mm	302 096	96 mm
302 066	66 mm	302 098	98 mm
302 068	68 mm	302 100	100 mm
302 069	69 mm	302 102	102 mm
302 070	70 mm	302 103	103 mm
302 075	75 mm	302 105	105 mm
302 077	77 mm	302 106	106 mm
302 078	78 mm	302 108	108 mm
302 080	80 mm	302 110	110 mm
302 085	85 mm	302 112	112 mm
307 085	85 mm	302 113	113 mm
Scania	Per assali SAF Ø est 109,7	302 114	114 mm
333 08501	85 mm	302 115	115 mm
Renault	Con diametro ribassato	302 116	116 mm
Mascot	.	302 118	118 mm
Traffic	.	302 120	120 mm
302 088	88 mm	302 123	123 mm
302 090	90 mm	302 135	135 mm
302 092	92 mm	302 140	140 mm
302 093	93 mm	302 160	160 mm SAF

## Chiavi a bussola con Esagono incassato, per GANCI ATTACCO LUPO

Hexagonal impact socket wrench for Lupo attack



1" Acc. Fosfatato

	Att"	Lunghezza	Esagono
302 063GL	1"	mm100	mm 63
302 065GL	1"	mm100	mm 65
302 070GL	1"	mm125	mm 70

## Chiavi a bussola Ottagonali

Octagonal impact socket wrench



1" Acc. Fosfatato

303 060	60 mm "bassa"	303 097	97 mm
303 06012	62 mm lunga mm 120	303 098	98 mm
303 065	65 mm	303 100	100 mm per Scania S4
303 070	70 mm	303 102	102 mm
303 075	75 mm	303 105	105 mm
303 078	78 mm	303 108	108 mm
303 080	80 mm	303 110	110 mm
303 082	82 mm	303 112	112 mm
303 083	83 mm	303 11201	112 mm Ribassata per assali ROR
303 085	85 mm	303 115	115 mm
303 08501	85 "bassa"	303 118	118 mm
302 086	86 mm per Scania S4	303 120	120 mm
303 088	88 mm	303 122	122 mm
303 090	90 mm	303 123	123 mm
303 094	94 mm	303 125	125 mm
303 095	95 mm	303 130	130 mm
303 096	96 mm	302 135	135 mm
		302 140	140 mm

## Chiavi a bussola Poligonali

Poligonal impact socket wrench



Acc. Fosfatato

1"

		Att:	Ø
304 06520	Per differenziale R.R Lunga mm 200	1"	mm 65
304 080	Cursor anteriore	1"	mm 80
304 085	Daily	1"	mm 85
304 090		1"	mm 90
304 095		1"	mm 95
304 100		1"	mm 100
304 105		1"	mm 105
304 110		1"	mm 110
304 115		1"	mm 115
304 120		1"	mm 120
304 130		1"	mm 130

## Chiave a bussola Poligonale con canotto

Poligonal impact socket wrench with guide



Acc. Fosfatato

1"

305 090	Nuovo Eurocargo - mm 90
305 095	Nuovo Eurocargo - mm 95
305 100	mm 100
305 105	Strailis - Cursor posteriore - mm 105
305 110	mm 110
305 115	mm 115

## Nuova chiave a bussola Poligonale impact con canotto sfilabile tramite grano

Poligonal socket wrench with removable tube via screw



Acc.  
Fosfatato

1"

305 10501	1" mm 105	*Per Iveco Stralis
-----------	-----------	--------------------

### Chiave a bussola Esagonale impact con canotto

Hexagonal impact socket wrench with tube



1"

	Att"	Esagono	
306 085	1"	mm 85	Per Eurocargo
306 090	1"	mm 90	
306 091	1"	mm 91,5	Per ponte Rockwell
306 095	1"	mm 95	
306 100	1"	mm 100	
306 105	1"	mm 105	
306 114	1"	mm 114	

### Bussola Ottagonale graduata per mozzi anteriori Scania

Octagonal impact socket wrench

Bussola graduata con marcatura laser  
Acc. Fosfatato



1"

307 080 Per mozzi Scania - Ottagono mm 80

### Bussola ESAGONALE con attacco 1", per assali SAF

Hexagonal impact socket wrench



Acc. Fosfatato



1"

307 085 Esagono mm 85  
\* Ø esterno mm 109,7

### Bussola esagonale pesante con foro di manovra trasversale

Hexagonal Socket



308 115 Lungh. mm 200 - mm 115

308 118 Lungh. mm 200 - mm 118

### Chiave per ghiera a 5 denti mozzi Bus "Breda Menarini"

Wrench 5 teeth for Bus "Breda Menarini"



Att 1"



	Ø Est. A	Ø Int. B	mm C	Att.
309 005	80	63	11,5	1"

### Chiave per ghiera a 10 denti mozzi Bus "Breda Menarini"

Wrench 10 teeth for Bus "Breda menarini"



Acciaio Zincato



Att 1"



	Ø Est. A	Ø Int. B	mm C	Att.
309 010	80	63	11,5	1"

### Chiave a T aperta per dadi tubazioni impianto di iniezione

T wrench polygonal open socket for nut pipe fitting



312 002	POLIGONALE aperta	17 mm
312 006	ESAGONALE aperta	19 mm

### Chiave aperte per dadi tubazioni impianto di iniezione

Open socket wrench for nut pipe fitting



- 312 012** POLIGONO aperto 19 mm "piega esterna"
- 312 016** ESAGONO aperto 17 mm "piega esterna"
- 312 019** ESAGONO aperto 17 mm "piega interna"

### Chiave esagonale aperta per valvola solenoide

Wrench exagonal open socket for solenoid valve



- 312 022** Bosh EP/VE - 24 mm

### Bussola extra-lunga per rimozione e montaggio pompa iniezione - Actros

Key for removal & mounting fuel injection pump



- 312 025** Att: 1/2" - Interno 12 punte x 10 mm

### Estrattori a colpo elettroiniettori Truck con ganascia basculante bloccabile tramite grano laterale

Extractor for electro injectors

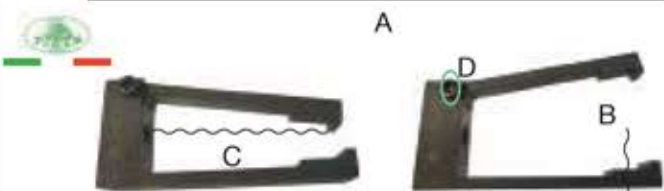

A mm    B m    C mm

- |                |     |         |    |           |
|----------------|-----|---------|----|-----------|
| <b>312 026</b> | 500 | 22 / 58 | 93 | Per Truck |
| <b>312 027</b> | 500 | 8 / 44  | 85 | Per Auto  |

### Set chiavi a 4 denti per montaggio-smontaggio ghiera iniettori Truck

Toothed socket for truck diesel pressure and injector man-mercede



- 312 028** In valigetta    Pz 4

### Chiave a 4 denti per ghiera porta iniettori Mercedes

Wrench for locking ring injector Mercedes



- 312 029**  
N° denti 4 - Larghezza dente mm 8 - Altezza dente mm 6  
Ø interno dente/dente mm 22 - Ø esterno mm 28  
Lunghezza chiave: mm 70



- 312 02910**  
N° denti 4 - Larghezza dente mm 8 - Altezza dente mm 6  
Ø interno dente/dente mm 23 - Ø esterno mm 29  
Lunghezza chiave: mm 140



- 312 030**  
N° denti 4 - Larghezza dente mm 8 - Altezza dente mm 6  
Ø interno dente/dente mm 22 - Ø esterno mm 27  
Lunghezza chiave mm 96



- 312 031**  
N° denti 4 - Larghezza dente mm 8 - Altezza dente mm 6  
Ø interno dente/dente mm 22 - Ø esterno mm 27  
Lunghezza chiave mm 160



- 312 03101**    Temprata  
N° denti 4 - Larghezza dente mm 8 - Altezza dente mm 6  
Ø interno dente/dente mm 28 - Ø esterno mm 32  
Lunghezza chiave mm 130

### Estrattore astucci portainiettori

Puller for nozzle holder



- 312 032**

## Estrattore astucci portainiettori

Nozzle holder puller



312 033

### Composizione - composition

- 312 03301 Puntale a sfera
- 312 03302 Estrattore filetto M 22 x 1,5
- 312 03303 Estrattore filetto M 3/4" GAS
- 312 03304 Estrattore filetto M 24 x 1,5
- 312 03305 Puntale con perno Ø 8,5 x mm 90
- 312 03306 Puntale con perno Ø 8,5 x mm 120

### Adattatori opzionali - Optional adapter

- 312 03322 Maschio creatore M 22 x 1,5
- 312 03323 Maschio creatore M 3/4" GAS
- 312 03324 Maschio creatore M 24 x 1,5



## Estrattore iniettori Bosch, Delphi, di facile utilizzo

Bosch, Delphi injector extractor



312 041

In valigetta

### Dati tecnici - Informative

Estrattore di facile utilizzo per iniettori Bosch, Delphi montati su: Mercedes, Volvo, Scania, Renault, Iveco, Man

## Attrezzo universale per ricalcatura astucci porta iniettori

Universal burnisher injectors sleeve



312 042

## Attrezzi distacco tubi carburante su serbatoi Iveco Stralis, Eurotech, Eurocargo e simili

Tool release fuel lines



312 051 Pz 3

### Ricambi - Spare parts

	A	B
312 051 01	11	35
312 051 02	14,5	35
312 051 03	17,5	35

## Estrattore / introduttore e svasatore campanine iniettori Volvo e Renault

Volvo (FM12) truck injector sleeve remover/installer



312 060

In valigetta

### Ricambi - Spare parts



312 06008 Puntale svasatore per campanine portainiettoiri Ø 8 - mm 100

## Estrattore campanine iniettori Volvo e Renault

Volvo truck injector sleeve remover/installer



312 062

## Chiave per montaggio cinghie puleggia refrigerante Freon 134, montata su veicoli Iveco Cursor

Iveco - Cursor tool for installing locking

**IVECO**



312 600

CURSOR 8-10-13

## Chiave filtro essiccatoio TRUCK a 3 denti perforanti



217 082 Chiave con tre tacche  
Ø esterno 155 mm - Ø interno 137 mm - Attacco quadro 3/4"

## Chiavi di grande potenza per rimozione filtri TRUCK

Filter removing tool for Truck

**IVECO**

**SCANIA**

**MAN**

**DAF**



217 08302 Per filtri olio Ø 100 - 110 mm Att:1/2"

217 08303 Per filtri olio Ø 110 - 125 mm Att:1/2"

217 08304 Per filtri essiccatoio Ø 125 - 140 mm Att:1/2"

## Estrattore a vite per campane iniettori TRUCK



141 25010

Estrattore con 2 boccole e 2 pinze

### Dati tecnici - Informative

Traversa: mm 185 con appoggi regolabili

Vite: mm 160

Completo di pinze: Ø 20 e Ø 27 e boccole: M 22x1,5 e M 24x2

Per Volvo e Renault pinza Ø 20

Per Iveco Boccola filettata M Ø 22 x 1,5 e Pinza Ø 27

Per Cursor 8 Boccola 22 x 1,5

Per Cursor 10 - 13 Boccola 24 x 2

### Ricambi - Spare parts

141 25011 Corpo porta pinze a vite lunga

141 25012 Piede di appoggio per traverse

141 25013 Boccola filetto maschio 22 x 1,5

141 25014 Boccola filetto maschio 24 x 2

141 220 Pinza ad espansione Ø 20

141 227 Pinza ad espansione Ø27



## Attrezzo rotazione albero motore per la registrazione delle punterie

Tool for engine rotation during clearance tappets

**IVECO**



313 002

Iveco 170

313 003

Iveco 330

313 004

Iveco 190.36

313 005

Iveco 190.42

### Attrezzo rotazione albero motore Mercedes Benz e MAN

Tool for engine rotation during clearance tapets



313 011

2 ingranaggi

#### Dati tecnici - Informative

Mercedes Benz: 6-8-10 cilindri - MAN: 12 cilindri  
Cod motori: 401, 404, 407, 409, 421, 424, 427, 444, 447

### Attrezzo rotazione albero motore Mercedes Benz e MAN

Tool for engine rotation during clearance tapets



313 012

3 ingranaggi

#### Dati tecnici - Informative

Mercedes Benz: Actros - Atego - MAN: 5 - 6 - 8 cilindri

### Attrezzo rotazione albero motore "DAF 105" (35-42Ton) (Euro 4 - 5)

Tool for engine rotation



313 013

Daf 105

### Attrezzo rotazione motore DAF - (35-42Ton) (Euro 4)

DAF flywheel rotator



313 01301

#### Dati tecnici - Informative

Codici motore: F65 - F75 - F85 - F95 - XF95 - 65CF - 75CF  
85CF - 95XF  
Attacco esagonale 24 mm - Altezza 90mm - Base 55mm  
Rotore: 11 denti Ø 41

### Attrezzo rotazione albero motore "SCANIA"

Tool for engine rotation



313 014

Scania

### Attrezzo rotazione motore per registro punterie con nuova piastra per modelli vecchi e nuovi Eurocargo Stralis - Motore Cursor 10 / 13

Tool for engine rotation during clearance tappets



313 018

Completo di doppia piastra

**Attrezzo rotazione motore per registro punterie per modelli Eurocargo Stralis dal 2004 - Motore Cursor 10 / 13**

Tool for engine rotation during clearance tappets



313 01801

**Attrezzo rotazione motore Volvo**

Motor rotation Volvo



313 021

**Dati tecnici - Informative**

Attacco quadro 1/2"  
 Rotore: 9 denti x Ø 34 mm  
 8 Fori x Ø 7,5  
 Distanza tra fori parte superiore: mm 56,0  
 Distanza tra fori parte inferiore: mm 116,5  
 Codici motore: FH-12 - FH-14 - D9A - -D12 - D16C

**Attrezzo per rotazione albero motore su Volvo FH 12 + Renault Mach 500 + Magnum**

Tool for engine rotation clearance tappets



313 023

**Dati tecnici - Informative**

Codici motore: MP8 - MP10 - FH12, D13 - A520

**Chiave registro vite bilancieri comando valvole**

Wrenches two rocher arm adjusting screw



- 313 025 14 mm con tacca
- 313 026 17 mm con tacca
- 313 027 17 mm con cacciavite

**Kit per anticipo fasatura albero a camme Eurocargo Iveco Stralis - motore Cursor 10 - 13 - euro 5**

Timing tool set Eurocargo Cursor 10 - 13



313 500 In valigetta

**Kit messa in fase Iveco Stralis - Motore Cursor "Euro 6"**

"Euro 6" Timing tool set for Iveco Cursor



313 510 Staffa con comparatore In valigetta

**Ricambi - Spare parts**

- 313 51010 Solo staffa
- 313 51011 Comparatore Ø 80 mm x corsa mm 100

**Chiave Torx per testata cilindri MAN**



B



Att:

- |         |      |        |      |
|---------|------|--------|------|
|         | Att: | A      | B    |
| 313 900 | 1/2" | mm 165 | E 20 |



# DIGITECH ITALIA

## Chiavi a bussola torx IMPACT attacco 3/4"

3/4" Torx socket

Crom Molibdeno - Brunita

3/4"



TORX - CORTE ( mm 70 )  
IMPACT

414 63418 E 18

414 63420 E 20

414 63422 E 22

\*Per testate autocarri MAN

414 63424 E 24

414 63428 E 28

414 63430 E 30

Per dado speciale su telaio  
Mercedes LKW



414 63432 E 32

Per braccetto sterzo



## Bussola Impact lunga per bullone albero motore Scania

3/4" SCANIA star impact socket E.28



414 63628 Att 3/4" Tx 28 E Lunghezza mm 110

## Estrattore canne cilindri

Remover and replacer sleeve



314 000 Completo di flange mm 121 + mm 137

314 001 Completo di flange:  
mm 121 + mm 137 + mm 124,5 + mm131,5 + mm143,5

### Ricambi - Spare parts

314 00010 Flangia mm 121

314 00013 Flangia mm 137  
NB: Utilizzabile solo in coppia con flangia da mm 121

314 00011 Flangia mm 124,5

314 00012 Flangia mm 131,5

314 00014 Flangia mm 143,5

## Attrezzo compressione e rilievo sporgenza canne cilindri

Tool for compressing and releasing cylinder



314 005 8340.04-8340.05-8360.05

## Supporto con comparatore per controllo altezza canne cilindri

Plate gauge for checking cylinder liner height

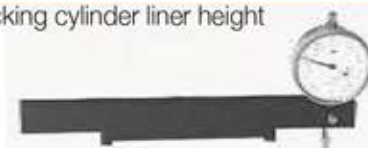

314 007 CO3, CP3, 8340.04, 8360.03, 8360.05

### Ricambi - Spare parts

314 008 Solo supporto

### Estrattore mozzo puleggia su albero motore

Puller crankschaft pulley hub



**314 009** 650, 662, 682, 690, 69NT, OM804, 693, 697, 690N4, 684, 691, 180

### Estrattore ritegno volano durante il fissaggio su albero motore

Flywhell restrainer



**314 012** Iveco 190 turbo

### Estrattore ingranaggio albero distribuzione

Puller for flywhell distribution



**315 001** Iveco 190, 190.42, 190.38, 170

### Introduttore paraolio albero motore Cursor 8

Cursor crankshaft oil seal coupler 8



**316 010**

Introduttore

### Campana inseritore guarnizione anteriore albero motore

Eurotech Eurostar F3A - F3B  
Cursor 10 / 13



**316 020**

Introduttore anteriore

### Attrezzo montaggio guarnizione posteriore albero motore

Eurotec Eurostar F3A - F3B  
Cursor 10 / 13



**316 030**

Introduttore posteriore

**DIGITECH**  
ITALIA

### Centrafrizione universale Truck

Universal tool for adjusting clutch plates truck



Acciaio - Brunito



321 010

Chiave Eurocargo



- 321 001 Kit con attrezzo + 6 boccole di centraggio
- 321 011 Kit con attrezzo + 6 boccole + chiave Eurocargo

#### Ricambi - Spare parts

- 321 010 Chiave centraggio frizione Eurocargo

### Attrezzo registrazione forcella comando splitter



- 322 010 ZF Ecosplit 16S, 130S, 160

### Estrattore albero e cuscinetti retromarcia

Puller for reverse shaft



- 322 021 Fuller 170 NC 33

### Chiave per ghiera albero frizione

Main shaft nut wrench



- 322 022 Fuller 170 NC 33

### Attrezzo sollevamento e bilanciatura albero primario e secondario



- 322 023 Fuller 170 NC 3

### Estrattore cuscinetto surmoltiplicata

Puller for bearing balls reduction gear



- 322 025 Fuller 170 NC 3

### Chiave dado fissaggio albero presa diretta

Wrench inputshaft nut



- 322 034 Fuller 170 NC 33-190 NC 33 - 80 mm

### Chiave ghiera albero di trasmissione

Wrench for mainshaft ring nut



- 322 040 190.42 - Ghiera Ø Est. 75 Ø Int. 68

### Chiave registrazione gioco cuscinetti conici albero secondario

Wrench adjusting bevel drive pinion locknut



- 322 042 OM 50-55-65-70-75-50 NC

### Chiave ghiera registro cuscinetti semiassi

Wrench for adjusting axle nut



- 322 043 626-640-642-Super Taurus

### Chiave ghiera presa diretta cambio flangiato

Wrench for mainshaft flange adjusting nut flanged only



- 322 046 E100 - 90 mm

### Chiave ghiera albero presa diretta cambio flangiato

Wrench for take off shaft adjusting nut only for flanged gearbox



322 048 E100

### Chiave ghiera albero presa diretta

Wrench for take off shaft adjusting nut



322 050 190.38 - 73 mm

### Chiave ghiera albero presa diretta

Wrench for take off shaft adjusting nut



322 052 Berliet - 68 x78x6

### Chiave a 4 denti per ghiera albero di trasmissione



3/4"

322 053 Dente 6 mm  
Interno dente - dente 65 mm Interno chiave 70 mm

### Chiave a 4 denti per ghiera albero Retarder



3/4"

322 054 Scania

#### Dati tecnici - Informative

N° denti: 4, Larghezza denti: 3,5 mm  
Ø Interno dente/dente: 41,5 mm x Ø interno chiave 54 mm  
Ø esterno chiave 63,5 mm - Altezza 74 mm - Att: 3/4"

### Chiave a 4 denti per ghiera albero Retarder



3/4"

322 055 Scania

#### Dati tecnici - Informative

N° denti: 4, Larghezza denti: 5 mm  
Ø Interno dente/dente: 59,5 mm x Ø interno chiave 72 mm  
Ø esterno chiave 83 mm - Altezza 101 mm - Att: 3/4"

### Chiave a 4 denti per ghiera cambio RETARDER



3/4"

322 056 Scania

#### Dati tecnici - Informative

N° denti: 4, Larghezza denti: mm 7  
Ø Interno dente/dente: 59 mm x Ø interno chiave mm 64,5  
Ø esterno chiave 77 mm - Altezza mm 62 - Att: 3/4"

### Chiave a 6 denti per ghiera RETARDER



3/4"

322 058 Renault

#### Dati tecnici - Informative

N° denti: 6, Larghezza denti: 7 mm  
Ø Interno dente/dente: 67,5 mm x Ø interno chiave 75 mm  
Ø esterno chiave 84 mm - Altezza 80 mm - Att: 3/4"

### Chiave a 6 denti per ghiera albero Retarder e mozzo posteriore Mercedes Sprinter 616



1"

322 059 Renault - Mercedes

#### Dati tecnici - Informativa

N° denti: 6, Larghezza denti: 9 mm

Ø Interno dente/dente: 90 mm x Ø interno chiave 100 mm

Ø esterno chiave 113 mm - Altezza 118 mm - Att: 1"

### Chiave a 4 denti per ghiera differenziale trattori DEUTZ



3/4"

322 060 Deutz

#### Dati tecnici - Informativa

N° denti: 4, Larghezza denti: 5,2 mm

Ø Interno dente/dente: 62 mm x Ø interno chiave 69 mm

Ø esterno chiave 84 mm - Altezza 105 mm - Att: 3/4"

### Chiave piatta per dado differenziale trattori DEUTZ

Flat Key for tractor differential Acc. Fosfatato



322 061	Bocca mm	Lunghezza mm	Spessore mm
	67	500	8

### Estrattore cuscinetti cambio

Puller for gearbox ball bearing



- 322 070 Universale Fiat Om
- 322 071 Estrattore a campana
- 322 072 Coppia semianelli 70 mm
- 322 074 Coppia semianelli 90 mm
- 322 075 Coppia semianelli 100 mm
- 322 076 Coppia semianelli 110 mm
- 322 080 Coppia semianelli/ 120 mm
- 322 078 Flangia per coppia semianelli sino 120
- 322 081 Coppia semianelli 130 mm
- 322 085 Coppia semianelli 138 mm
- 322 082 Coppia semianelli 140 mm
- 322 083 Coppia semianelli 150 mm
- 322 084 Coppia semianelli 160 mm
- 322 086 Flangia per coppia semianelli sino 160

### Estrattore per cuscinetto posteriore scatola del cambio Z-F Retarder

Puller rear bearing gearbox Z-F with retarder



322 090 In scatola

**DIGITECH**  
ITALIA

**Attrezzo per estrazione e introduzione albero primario, secondario e gruppo forcella cambio ZF 16 marce 151 - 181 - 221**

Puller countershaft



322 092

**Estrattore scatola idroguida, in acciaio temprato, per Scania & Iveco**

Puller, roller bush arm

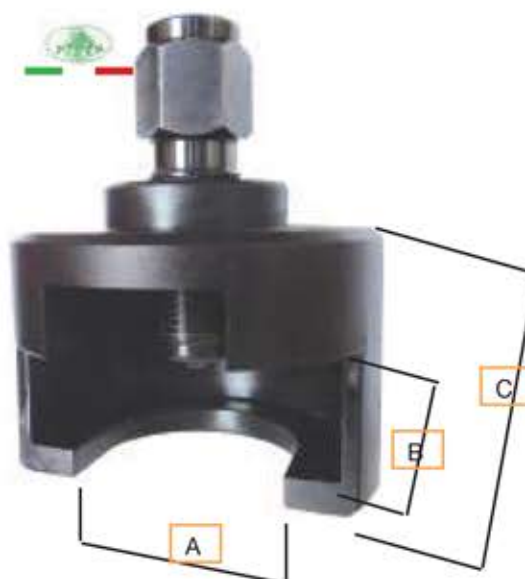

331 000 A mm 81 B mm 44 C mm 98

**Estrattore flangia pignone conico**

Puller for bevel pinion

322 110

322 111



322 110

Per 190 Turbo

322 111

Ø 180 mm

682-697-684

**Estrattore volante guida**

Puller driving well



331 003

Fornito con 2 coppie di tiranti Ø 8, Ø 10

**Chiave braccetti sterzo TRUCK**



414 74599

Att. 3 / 4" - Torx 100

**Chiave rotazione braccio tirante sterzo**

Bar loosening tool



331 010

Universale

### Chiave valvole compressore

Wrench for compressor



331 011	Marelli OM FIAT
331 013	626-642-666-680-682
331 015	Westinghouse

### Chiave ghiera sterzanti

Wrench for nut steering pads



331 017 Adige Viberti

### Estrattore barre di reazione fra i due ponti

Puller for rear wheel reaction rod



333 008 693-697-300

### Chiave registro cuscinetto mozzo ruote posteriori



333 050 Universale registrabile

### Estrattore perni a sfera, in acciaio CR.V. temprato

Universal Ball joint pullers



332 000 A mm 41 B mm 77 C mm 87,5

### Chiave a bussola Esagonale impact con canotto



Acc. Fosfatato

1"



	Att"	Esagono	(Ex cod 333 051)
306 085	1"	mm 85	Per Eurocargo

### Chiave registro cuscinetto mozzo ponte intermedio

Spanner for medium wheel hub bearings adjusting collar or nut



333 007 697N-300PC-Titano6x4-OM260-300-418-421 90 mm

### Chiave dado mozzo ruote

Spanner for wheel nut



333 052 Eurocargo - 65 mm  
333 053 Eurocargo Eurotek - 95 mm

### Estrattore mozzo ruote

Puller for hubs



- 333 056 Iveco 115.17 Ant.
- 333 057 Iveco 115.17 Post. rear
- 333 058 Iveco 109-115-135-145 Ant.
- 333 059 Iveco 109-115-135-145 Post. rear

### Chiave per dadi mozzi BPW ECO



Acciaio -  
Brunito



- 333 062 Att. 1" - mm 65
- 333 063 Att. 1" - mm 80

### Chiave per copri mozzi BPW



1"



- 333 064 BPW ECO mm 110 x mm 106  
Per coprimozzo con filetto M - 125 x 2  
Per coprimozzo con filetto M - 135 x 2
- 333 067 VIBERTI mm 109 x mm 104
- 333 068 BPW mm 110 x mm 104
- 333 069 BPW mm 95 x mm 90
- 333 070 BPW mm 94 x mm 89
- 333 071 BPW ECO mm 120 x mm 115
- 333 07110 BPW ECO mm 120 x mm 115 C/K

**DIGITECH**  
 ITALIA

### Chiave ghiera mozzo ruote posteriori

Wrench for rear hubs nut



- 333 072 Mercedes 1113-1117-1217 - 84 mm



### Chiave ghiera mozzo posteriore Mercedes G.1324

Wheel hub bearing socket



3/4"



- 333 07306

#### Dati tecnici - Informative

Attacco: 3/4"  
 N° denti: 6  
 Larghezza dente: 11 mm  
 Ø Interno dente/dente: 93 mm    Ø esterno dente/dente: 106  
 Ø Canotto esterno: 57 mm    Ø Canotto interno 52

### Chiave per ghiera mozzi con canotto

333 074

333 075



- 333 074 6 Denti - Int./Est. Ø 98 / 106 Largh. 14

- 333 075 Mercedes 814



### Chiave per ghiera 6 Denti mozzi poster. MAN ALE



Acciaio -  
Zincato



Att 1"

	Ø Est. A	Ø Int. B	mm C	Att.
333 076	118	110	11 x 4,5	1"
333 079	124	117	9,5 x 3	3/4"

### Chiave ghiera mozzo posteriore

Socket for wheel hub bearing

**IVECO**



333 077 12 Denti Ø int. 99 Ø est. 105

### Chiave ghiera mozzo ruote posteriore Mercedes

Wheel hub bearing socket



3/4"



333 078

#### Dati tecnici - Informativi

Attacco: 3/4" - N° denti: 12 - Larghezza dente: 11,9 mm  
 Ø Interno dente/dente: 101 mm Ø esterno dente/dente:  
 110 Ø Canotto esterno: 51,9 mm Ø Canotto interno 44,4

### Chiave ghiera mozzo ruote posteriori

Ø 112-98x92 C.61-55



333 080 Mercedes 0404-man 12-332 8 denti - 98 mm

### Chiave per ghiera 8 Denti. Per mozzi



Acciaio -  
Zincato



Att 1"

	Ø Est. A	Ø Int. B	mm C	Att.
333 081	106	95	8	1"

### Chiave mozzi posteriori Mercedes Actros e asse centrale Atego 1828

Key for hubs Mercedes Actros and e center line Atego



1"



333 082 Mercedes - Atego

#### Dati tecnici - Informativi

N° denti: 6 - Larghezza dente: 9 mm - Altezza dente 10 mm  
 Ø Interno dente - dente 117 mm - Ø Interno 110 mm  
 Ø esterno chiave 130 mm  
 Ø Canotto Esterno 65 mm - Ø Canotto interno 55,0 mm  
 Altezza mm 190 - Att: 1"

### Chiave per ghiera 6 Denti interni per mozzi



Acciaio -  
Zincato



Att 1"

Ø Est. A    Ø Int. B    Ø Int. C    mm D

333 083    112    98    89    8

### Chiave ghiera mozzo posteriore

Socket for wheel hub bearing



333 084    12 Denti interni - Mercedes Bus 303 - 99x108

333 086    6 Denti interni - Breda - 100x110

333 087    6 Denti interni - 121x131

### Chiaveghiera 4 denti mozzo posteriore Renault Mascot & Trafic

4 tooth socket for wheel hub bearing

Att. 3/4"



mm 130

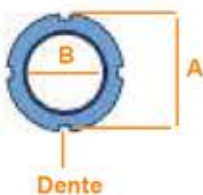

Att.    Dente    A esterno    B interno

333 085    3/4"    13    mm80    mm 65

### Bussola Esagonale ribassata per mozzo posteriore

Renault Mascot e Trafic



Acc. Fosfatato

1"



333 08501    Att"    Esagono    Lunghezza

1"    mm 77    m 130

\*Con esterno Ø 95 mm, ribassato per modelli Renault

### Chiave ghiera 6 denti per assale posteriore SCANIA



1"

333 088

N° denti: 6 , Larghezza denti: mm 11,5

Ø interno dente - dente 122 mm - Ø interno chiave 131 mm

Ø Canotto Esterno 70,8 mm - Ø Canotto interno 57,6 mm

Ø Canotto Esterno 70,8 mm - Ø Canotto interno 57,6 mm

### Chiave per ghiera mozzi bus Mercedes Citaro



3/4"

333 089

In materiale temprato

N° denti: 6 - Larghezza denti: 10 mm -

Altezza dente: 9 mm ( 5 x 45° )

Ø Interno dente/dente: 122 mm

Ø esterno dente/dente: 140

Altezza bussola : 180 mm

**Chiave a 4 denti per ghiera registro cuscinetti mozzi anteriori Daily dal 2014**



**3/4"**

**333 091** Daily 99355185  
 N° denti: 4 , Larghezza denti: mm 6,5  
 Ø Interno dente/dente: 63 mm x Ø interno chiave mm 73,1  
 Ø esterno chiave 85 mm - Altezza mm 50 - Att: 3/4"

**Chiave per ghiera anteriore bus Iveco Citelis**

Key for locking ring Bus Iveco Citelis



**333 093** In materiale temprato  
 Attacco Esagonale: 36 mm  
 N° denti: 6 -  
 Larghezza denti: 10,5 mm - Altezza dente: 11 mm  
 Ø Interno dente/dente: 72 mm  
 Ø Esterno dente/dente: 85 mm

**Chiave con canotto removibile tramite grano. Per ghiera anteriore Mercedes Sprinter.**

Wrench for Mercedes Sprinter



**1"**

**333 097**  
 N° denti: 6 -  
 Larghezza dente: 7,5 mm - Altezza dente 10 mm  
 Ø Int. dente - dente 62,5 mm - Ø est. chiave 75 mm  
 Ø Canotto Esterno 42 mm - Ø Canotto interno mm 33  
 Altezza con canotto mm 190 - Altezza senza canotto mm 67

**Chiave per perni balestre Volvo**

Tool for leaf spring pivot



**333 101**

**Coppia perni balestre SCANIA**



**333 10110**

**Estrattore cuscinetti mozzi posteriori**

Puller for rear hubs ball bearing



**333 110** Volvo F12

**Estrattore cuscinetti mozzi**

Puller for hubs ball bearing



**333 114** 330-190.38-190.35 Turbo

**DIGITECH**  
 ITALIA

### Chiave calotte mozzo ruote

Wrench for hubs nut



333 130	619N - 60 mm
333 132	682-692 - 65 mm
333 134	Leoncino35/40-50-55-60-65-70-75-329 - 70 mm
333 136	680-682N4-690N1/N4-306-411-180NC - 100 mm
333 138	102 mm
333 139	682N2 - 130 mm
333 140	Viberti-Card - 140 mm



Chiave a 6 denti con 2 tubolari intercambiabili tramite bloccaggio con un grano laterale.

\*MAN TGA e M.B 10 + 13 Ton

\*Assale portante e ipoide nr 7/4 (senza guide tubolari) \*Autobus 0305G, 0405G



3/4"

Esempio chiavi con tubolare inserito

333 149	Scania
N° denti: 6, Larghezza denti: 11,5 mm	
Ø Int. dente/dente: 101,5 mm x Ø int. chiave 95 mm	
Tubolare: Ø esterno 51,8 x Ø interno 46 x L 140 mm	
Tubolare: Ø esterno 66 x Ø interno 60 x L 140 mm	
Ø esterno chiave 114 mm	
Altezza chiave senza tubolare: 112 mm	
Altezza chiave con tubolare: 165 mm	

### Chiave a 6 denti con canotto removibile, ideale per mozzi posteriori su mezzi Mercedes Actros

Wrench for rear hubs on Mercedes Actros vehicles



mm  
200



3/4"

#### 333 150

N° denti: 6 - Larghezza dente: mm10 - Altezza dente mm 10  
 Ø Interno dente - dente 117 mm - Ø esterno chiave mm 125  
 Ø Canotto Esterno mm 60 - Ø Canotto interno mm 55  
 Altezza con canotto mm 200- Altezza senza canotto mm 165

### Chiave a 6 denti esterni con canotto + canotto maggiorato ( per asse posteriore )

Per: Mercedes benz ATEGO HL2, 814 Vitaro 814 - MAN ecc...



Particolare del canotto maggiorato da calzare sul canotto originale



Int. Ø 49,1

Est. Ø 57

3/4"

#### 333 152

Per Benz e MAN In scatola

N° denti: 6 (esterni), Larghezza denti: 10 mm  
 Ø Interno chiave (da dente a dente) 87 mm  
 Ø Esterno chiave 95 mm  
 Altezza chiave: 175 mm  
 Canotto: Ø Int. 40 - Ø Est. 49  
 Canotto maggiorato: Ø Int. 49,1 - Ø Est. 57

#### 333 15201

Solo canotto maggiorato ( Ricambio )

**Chiave per ghiera con 6 denti interni  
Asse anteriore MAN TGA**



**3/4"**

**333 153**

N° denti: 6 (interni), Larghezza denti: 7 mm  
 Ø Interno chiave: 100 mm  
 Ø Interno chiave (da dente a dente) 93 mm  
 Esterno chiave 109 mm  
 Altezza chiave: 79 mm

**Chiave ghiera 6 denti con canotto removibile  
tramite grano.**



**1"**

**333 157**

Mozzo posteriore MAN - TGA, V9 - 82L,  
 Freni a disco / ABS ecc..

N° denti: 6 , Larghezza denti: mm 11,5  
 Ø Interno dente - dente 117 mm - Ø Interno chiave 132 mm  
 Ø Canotto Esterno 70 mm - Ø Canotto interno 57,6 mm  
 Altezza mm 145 - Att: 1"

**Estrattore leva comando frizione sterzo trattori**

Puller for lever on  
 clutch steering wheel  
 tractors



**333 200** 52-55-60-70-80-FL

**Estrattore pignone su piatto frizione sterzo trattori**

Puller for pinion on plate  
 on clutch steering wheel  
 tractors



**333 202** 52-55-60-70-80-FL

**Estrattore tamburo interno frizione sterzo trattori**

Puller for axle on clutch steering wheel tractors



**333 204** 52-55-60-70-80-FL

**Estrattore molle frizione sterzo trattori**

Puller for coils on clutch steering wheel tractors



**333 206** 52-55-60-70-80-FL

**Estrattore perni di giunzione catenarie trattori**

Puller for pins of chaintractors



<b>333 210</b>	25C-311-312-352-531	10x1.25
<b>333 211</b>	411-451	14x1.5
<b>333 212</b>	OM35-40-45-50C	16x1.5
<b>333 213</b>	52-55-60-70-80-FL	20x1.5

## Estrattore tamburi ceppi freno

Puller for brake hubs



- 333 215 Universale  
333 216 Zampa Ricambio

### NOTE



## Estrattore a traversa chiusa per mozzi e tamburi freno TRUCK, fornito con 5 coppie di tiranti intercambiabili

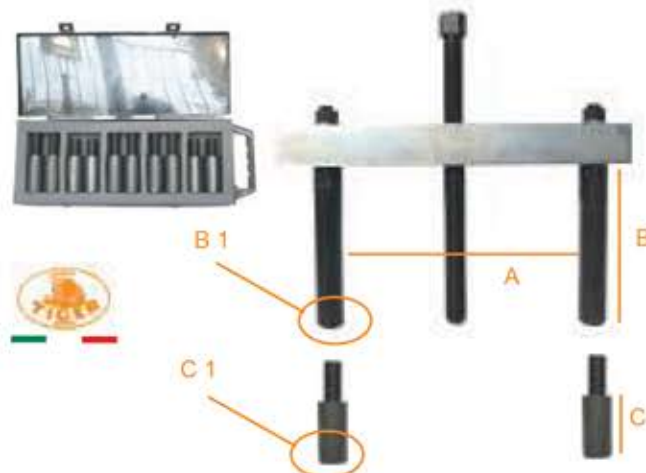

- 333 230 Estrattore fornito con 5 coppie di tiranti  
A min 140 - max 370 - 15 Kg

### Ricambi - Spare parts

- 333 230 05 kit 5 tiranti in comoda valigetta  
( di serie con 333 230 )

		B 1	B
333 230 22	Coppia colonne	22 x 1,5	200
		C 1	C
333 230 18	Coppia tiranti	18 x 1,5	70
333 230 20	Coppia tiranti	20 x 1,5	70
333 230 21	Coppia tiranti	20 x 2	70
333 230 78	Coppia tiranti	11G 7/8"	70
333 230 79	Coppia tiranti	14G 7/8"	70

### Adattatori opzionali - Optional adaptor

		B 1	B
333 230 23	Coppia colonne	22 x 1,5	100



Particolare del tirante con prigioniero filetto femmina per mozzi e tamburi Truck

### Esempi di utilizzo - Examples of use

#### Motrici:

- Coppia tiranti mm 18 x 1,5
  - Coppia tiranti mm 20 x 1,5
  - Coppia tiranti mm 22 x 1,5
  - Coppia tiranti mm 18 x 1,5 / 20 x 1,5 / 22 x 1,5
  - Coppia tiranti 7/8"
- Iveco Daily  
Mercedes  
Astra - DAF - Renault - Mercedes  
Iveco Truck  
Scania - Volvo

#### Rimorchi e semirimorchi:

- Coppia tiranti mm 22 x 1,5
  - Coppia tiranti mm 20 x 2
  - Coppia tiranti 7/8"
- Acerbi-fruehauf / Adige-umberti  
Austeras / Bartoletti / Battaglino-bpw / BPW / Cardi / Minerva  
ROR-meritor / Otto saver saf  
Raggiere Adige viberti  
Battaglino-bpw



**DIGITECH**  
ITALIA

## Kit carrellato per estrazione ed introduzione boccole in acciaio, bronzine e SILENTBLOCK dalle balestre

Hydropneumatic puller / tacker-in for busching and silentblock



**334 214** Carrello con pompa, adattatori e pistone 15.T

**334 21400** Carrello con pompa, adattatori e pistone 30.T

### Composizione - Composition

**334 21404** Solo carrello

**334 21405** Pistone idraulico NUDO - 700B. 15T

**334 21406** Pistone idraulico 15 ton. a 2 vie con attacchi

**334 214VC** Spezzone vite mm 200

**334 214VL** Spezzone vite mm 350

**334 21403** Kit tubi, adattatori, boccole - Pz.13

Composizione articolo 334 21403:

334 214A	TUBO Ø 65X55X136
334 214B	TUBO Ø 70X65X93
334 214C	ANELLO Ø 80,0-30,5X12
334 214D	ADATTATORE Ø 34,8-29,3X24
334 214E	ADATTATORE Ø 39,8-34,0X24
334 214F	ADATTATORE Ø 41,9-34,5X24
334 214G	ADATTATORE Ø 44,8-39,8X24
334 214H	ADATTATORE Ø 49,6-44,5X24
334 214I	ADATTATORE Ø 53,7-44,5X24
334 214J	ADATTATORE Ø 59,5-49,2X24
334 214K	Boccola filett. Ø 27X45-20X1,5
334 214L	Boccola filett. Ø 30X45-20X1,5
334 214M	Boccola filett. Ø 32X45-20X1,5

**334 301** Pompa pneumo-idraulica da 700 bar senza attacchi

**334 30201**  Attacco Maschio da 700 bar  
Femmina.1/4" npt  
Venduto singolo. (2 pz per kit)

**334 30202**  Attacco Femmina da 700 bar  
Maschio 1/4" npt  
Venduto singolo. (2 pz per kit)

**334 30203** Tubo Mt.2 singolo da 700 bar - .1/4" npt - F.1/4"Gir. (2 pz. per kit)

**334 30210**  Nipple M.1/4" - M.1/4"  
Venduto singolo (2 pz. per kit)

## ADATTATORI OPZIONALI 334 214

**334 224** Kit boccole per rimorchi e semirimorchi - Pz. 5

Dettaglio:

334 224A	TUBO Ø99,5-85,6x125
334 224B	ANELLO Ø84-31x9
334 224C	PRESSORE Ø56-30-20,5x30
334 224D	PRESSORE Ø67-30-20,5x30
334 224E	PRESSORE Ø80-30-20,5x30

**334 234** Kit boccole IVECO Pz.11

Dettaglio:

334 234A	TUBO Ø70-59,5-56x110
334 234B	TUBO Ø75-63-60x120
334 234C	TUBO Ø60-48-45X100
334 234D	TUBO Ø70-57-53X110
334 234E	PRESSORE Ø69,5-50,5-45,0X34
334 234F	PRESSORE Ø69,5-50,5-43,2X35
334 234G	PRESSORE Ø69,5-50,5-42,0X35
334 234H	PRESSORE Ø54,8-36,5-24,2X22
334 234I	PRESSORE Ø59,5-39-24,2
334 234L	PRESSORE Ø61,8-39-8
334 234M	PRESSORE Ø70-39-24,2

## ADATTATORI OPZIONALI 334 214



**334 21416** Att.20x1,5 / Riduz.16x2 Vite con riduzione

\* Utilizzabile con pistoni: 334 21405 e 334 21430

## ADATTATORI OPZIONALI 334 214



**334 21430** Pistone 30 Ton Senza attacchi

**334 21431** Pistone 30 Ton Fornito attacchi Femmina 700 bar

**DIGITECH**  
ITALIA

**Cilindro a doppio effetto con trazione centrale e FORO PASSANTE.**  
**Utilizzabile con una barra filettata Ø24 max**



334 21450

**Dati tecnici - Informative**

- \* Lunghezza stelo 390 mm
- \* Ø stelo esterno 35 mm - Ø stelo interno 25 mm
- \* Corsa stelo: 90 mm - Ø cilindro 105 mm
- \* Lunghezza cilindro 260 mm - Peso: 12 Kg

La base di appoggio e reazione va creata in base al lavoro da svolgere, appoggiando il lato interessato del pistone a cilindri di ferro di alto spessore

**Pompa doppio effetto da 700 bar utilizzabile con nostri:**  
**334 214 kit carrellato estrazione boccole / silent block**  
**334 300 e 334 33010 Kit estrattori perni**



334 301 Pompa "nuda"

**ADATTATORI OPZIONALI - Optional**

- 334 30201  Attacco rapido maschio 700 bar  
Femmina 1/4" npt
- 334 30202  Attacco rapido F. 700 bar  
Maschio 1/4" npt
- 334 30204  Tappo di chiusura per  
334 30202
- 334 30203  Tubo da 700 bar - Mt.2 M.1/4" npt x F.1/4" gir.
- 334 30210  Nipplo "Venduto singolo"  
M.1/4" cil. X M.1/4" cil.



**Estrattore completo di pompa per PERNI FUSI montati su rimorchi, semirimorchi, motrici e simili**

Pin extractor, conceived in order to draw pins out of trailers or semitrailers suspensions

**Carrello 334 350 venduto separatamente**



334 30010 Attrezzo completo di pompa da 700 bar con attacchi e pistone da 75 Ton

**Ricambi - Spare parts**

- 334 30011 Pistone idraulico 75T
- 334 301 Pompa 700 atm senza attacchi - Lt 2.5
- 334 302 Attacchi completi 700B con rubinetti F / M
- 334 303 Kit 3 adattatori perni fusi

**Adattatori opzionali - Optional adaptor**

334 30105 Pompa 700 atm senza attacchi - Lt.5.0

**Dati tecnici - Informative**

**ESTRATTORE PERNI FUSI**

L'estrattore è composto da un pistone idraulico flangiato azionato da una centralina pneumatica e due barre filettate per consentire all'operatore di posizionare la staffa nella posizione opposta del pistone, in modo da far lavorare lo stesso perpendicolare alla base piatta del perno fuso. Le barre filettate consentono di estrarre perni di grandi e medie dimensioni.

L'estrattore è inoltre fornito di PUNZONI, di varie misure, variabili a seconda delle dimensioni del perno



**Carrello NUDO OPZIONALE da utilizzare con estrattori perni fusi ( 334 300 / 334 30010 )**



**334 350** SOLO CARRELLO per 334 30010

**Dati tecnici - Informative**

**CARRELLO PORTA ESTRATTORE PER PERNI FUSI**

Grazie alla struttura con un solo braccio curvo, l'operatore può raggiungere i perni fusi nelle posizioni più insidiose, in quanto un lato è completamente libero. I movimenti basculanti del braccio e la regolazione dell'altezza consentono la movimentazione e il posizionamento senza particolare difficoltà per l'operatore.

Dimensioni: Larghezza mm 1100 x Lunghezza mm 1400



**DIGITECH**  
ITALIA

**Leve per aggancio molle freni autocarri**

Forged tool for brake release spring without desmonting the plate. Available in 2 length

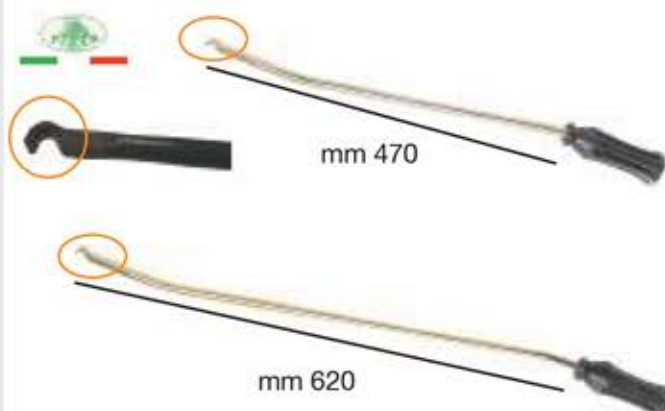

**335 00510** Kit 2 leve

**Composizione - Composition**

**335 004** Leva mm 470 (per IVECO)

**335 005** Leva mm 620

**Attrezzo registro freni**

Tool for adjusting cylinder brake



**335 006** Stop master

**335 008** Nuovi impianti

**Calettatore per montaggio guarnizioni di tenuta cilindri freno**

Installer for brake cylinder seal



**335 010** Stop master

**335 011** Eurotech

**335 012** Eurocargo

### Attrezzo registro freni

Brake cylinder adjusting tool



335 015

Stop master

### Attrezzo registro freni

Brake cylinder adjusting tool

335 016



335 017

335 016

Stop master

335 017

Stop master

### Attrezzo per la regolazione dei freni Ø 15

Tools for remover shoe spring Ø 15



335 018

Lunghezza mm 380

### Bussola pinza freni Volvo trucks

Brake caliper socket on Volvo trucks



335 019

Volvo Trucks

#### Dati tecnici - Informative

\*Att.3/8" - Misura: 11 tacche - L. bussola 26mm

\*Usata su pinze Knorr-Bremse, modello SB, SK, SN, generalmente montate su rimorchi: Daf, Foden, Man, Mercedes, Scania, Bova, plus BPW & SAF

### Bussole Torx con esagono



335 020

Torx E 20

Esagono mm 30

335 021

Torx E 24

Esagono mm 30

### Leva registro freni a mano DAILY



335 025

### Chiave poligonale a percussione per freni Truck

413 570 17 mm

413 571 18 mm

413 572 19 mm

413 573 21 mm



### Alesatori montanti fusi a snodo

Reamer knuckle bush



335 100 110-130-100/10-650N-662 27x34 mm

335 102 160-643-684 32x40 mm

335 104 Gamma Z 34x42 mm

335 106 170-190-418-421-370-150NC 41,3x50.8 mm

335 108 Arcom-Battaglino-Marotta190-260 45x50 mm

335 110 Ceschi-Rigo 47x52 mm

335 112 Calabrese 50x55mm

335 114 Arcom 50x60 mm

335 116 Zorzi 51x56 mm

335 118 Arcom 55x60 mm

335 120 Ceschi-Rigo 65x72 mm

### Moltiplicatore di coppia manuale per TRUCK

Increasing length save labour wrench



335 200 In valigetta

#### Dati tecnici - Informative

Moltiplicatore di coppia con bussole da mm 32 & 33 attacco 1" Utilizzato per rimuovere i bulloni di tutti i tipi di ruote dagli autocarri. Semplice da utilizzare e facile da trasportare grazie alla sua valigetta. Forza massima 4800 Nm, pari a 480 Kg.

### Chiave a girabacchino dado fissaggio ruota

Wrench for wheels nuts



- 335 321** Lung. 370 - Bocca 27 mm
- 335 322** Lung. 370 - Bocca 27 mm - Con unghia
- 335 325** Lung. 370 - Quadro 3/4" - Con unghia

### Chiavi doppie per dadi ruota truck

Tool for cylinder brake      Acciaio - Cr. V - Zincato



- |                  |                   |          |
|------------------|-------------------|----------|
| <b>335 35000</b> | Chiave senza asta | mm 24X27 |
| <b>335 35040</b> | Con asta mm 400   | mm 24X27 |
| <b>335 35050</b> | Con asta mm 500   | mm 24X27 |
|                  |                   |          |
| <b>335 35200</b> | Chiave senza asta | mm 27X30 |
| <b>335 35240</b> | Con asta mm 400   | mm 27X30 |
| <b>335 35250</b> | Con asta mm 500   | mm 27X30 |
|                  |                   |          |
| <b>335 35400</b> | Chiave senza asta | mm 27X32 |
| <b>335 35440</b> | Con asta mm 400   | mm 27X32 |
| <b>335 35450</b> | Con asta mm 500   | mm 27X32 |
|                  |                   |          |
| <b>335 35600</b> | Chiave senza asta | mm 30X32 |
| <b>335 35640</b> | Con asta mm 400   | mm 30X32 |
| <b>335 35650</b> | Con asta mm 500   | mm 30X32 |
|                  |                   |          |
| <b>335 35800</b> | Chiave senza asta | mm 32X33 |
| <b>335 35840</b> | Con asta mm 400   | mm 32X33 |
| <b>335 35850</b> | Con asta mm 500   | mm 32X33 |

### Chiave a bussola sblocco cabina IVECO



- 336 000**      3/4" Ø int.30      Chiave di manovra 22

### Estrattore a colpo per perni cabina "DAF"

Puller for pins cabin "DAF"



mm 800

- 336 050**      Estrattore completo di adattatore e perni

Ricambi - Spare parts

- 336 05003**      Kit 3 perni Maschio / Maschio
- 336 05008**      M. 8 x 1,25 - M 20 x 1,5
- 336 05010**      M.10 x 1 - M 20 x 1,5
- 336 05012**      M.12 x 1,75 - M 20 x 1,5

- 241 03502**      Adattatore F.20 x 1,5 - F 20 x 1,5 (N°4)

### Coppia di vaschette raccogli olio mozzo posteriore

Truck & trailer couple wheel pan



Pratico foro per espellere il liquido



- 336 100**      Coppia di vaschette

Ricambi - Spare parts

- 336 10003**      Vaschetta singola da 3 lt.
- 336 10006**      Vaschetta singola da 6 lt.

**Kit per spurgo e ricarica per radiatori**  
Composto da attacco rapido, 1,5 mt. di tubo e  
rubinetto portagomma con valvola apri / chiudi

Bleeding / recharging radiators kit



340 000	SCANIA 3
340 001	SCANIA 4
340 002	SCANIA serie S - Anno 2018
340 005	VOLVO



NOTE



**Pompa per riempimento e spurgo 3° asse sterzante**

Pump for filling and draining 3rd axis



340 060 Pompa per spurgo 3° asse sterzante

**Adattatori opzionali - Optional adaptor**

- 340 061 Kit spurgo 3°asse sterzante IVECO
- 340 062 Kit spurgo 3°asse sterzante VOLVO
- 340 064 Kit purgo 3°asse sterzante SCANIA
- 340 065 Kit spurgo 3°asse sterzante Man
- 340 066 Kit tubi spurgo 3° asse  
MERCEDES (olio DOC4)
- 340 067 Kit raccordi spurgo 3°asse sterzante DAF
- 340 068 Kit raccordi spurgo 3° asse  
sterzante RENAULT
- 340 069 Kit raccordi spurgo leveraggio marce  
Mercedes ( Olio DOC4 )
- 340 070 Kit raccordi spurgo leveraggio marce  
Olio Pentosil su Mercedes e MAN



**DIGITECH**  
ITALIA

## Cavalletto regolabile di grande portata ma ad altezza ridotta per sostegno Autobus / Truck

Jack stand



Per cavalletti vedi anche sez.15

	Portata	Alzata min	Alzata max
<b>522 01820</b>	10 Ton	200 mm	300 mm
<b>522 01830</b>	10 Ton.	300 mm	500 mm

## Kit per ripristinare i filetti dei mozzi ruota Truck

Wheel stud thread restorer



**512 276** Kit 5 pezzi in valigetta

### Dati tecnici - Informative

18 x 1,5 Daf - Iveco - Man - Renault - Volvo  
 20 x 1,5 Mercedes - Scania  
 22 x 1,5 Daf - Man - Renault - Volvo - Mercedes - Scania - Ford  
 7/8" Scania

## Set riparazione filetti mozzi Truck

Truck hubs thread repair set



**512 277** In valigetta

### Dati tecnici - Informative

Attrezzo semplice da usare, ottimo per raddrizzare filettature ammaccate o deformate degli assali, alberi cambio, mozzi ruote ecc.. Possibilità di impiego su alberi da Ø20 a Ø100mm sia per filetti destri che filetti sinistri.

Completo di 16 rulli facilmente intercambiabili con passo: Ø1,5 - 2 - 2,5 destri e Ø1,5 sinistro

### Ricambi - Spare parts

**512 27715** Set 4 rulli Filetto 1,5

**512 27720** Set 4 rulli Filetto 2,0

**512 27725** Set 4 rulli Filetto 2,5

**512 27730** Set 4 rulli Filetto 3,0

**512 27815** Set 4 rulli Filetto SX 1,5

## Estrattori perni sferici tiranti sterzo Truck. Nuovo modello rinforzato con pratica impugnatura ergonomica

Ball joint puller of tierods for Truck

Per estrazione perni sferici vedi anche sez.1



**151 174** A: 27mm B: 28mm L: 260mm

**151 175** A: 25mm B: 34mm L: 260mm

**151 176** A: 21mm B: 43mm L: 260mm